

MODEL:

RB-3311S-GBS

RB-3312S-GBS

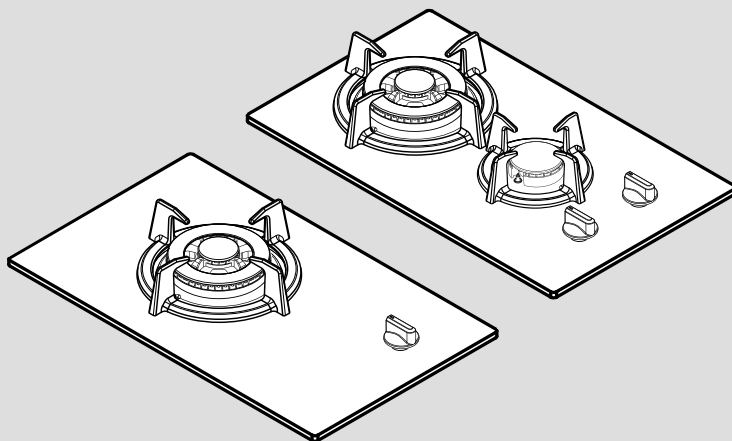

Gas Built in Hob

Instruction for use

Rinnai

In order to obtain the best results and to maintain your Rinnai gas cooker in the best condition, please read the instruction carefully.

Components and parts names

RB-3311S-GBS

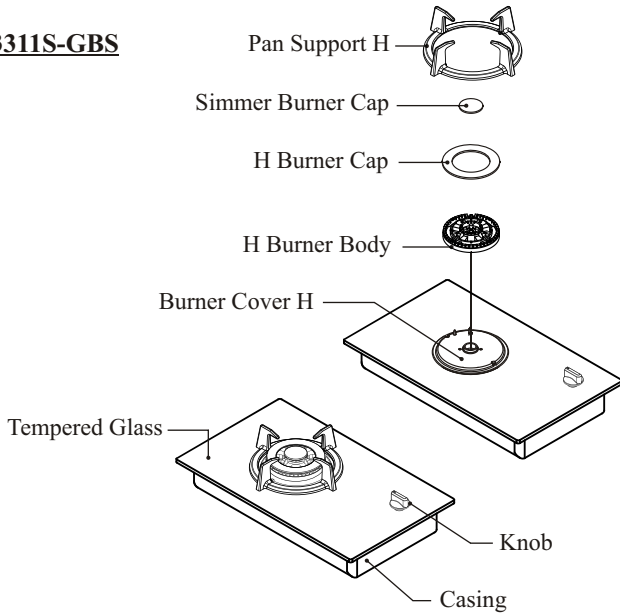

RB-3312S-GBS

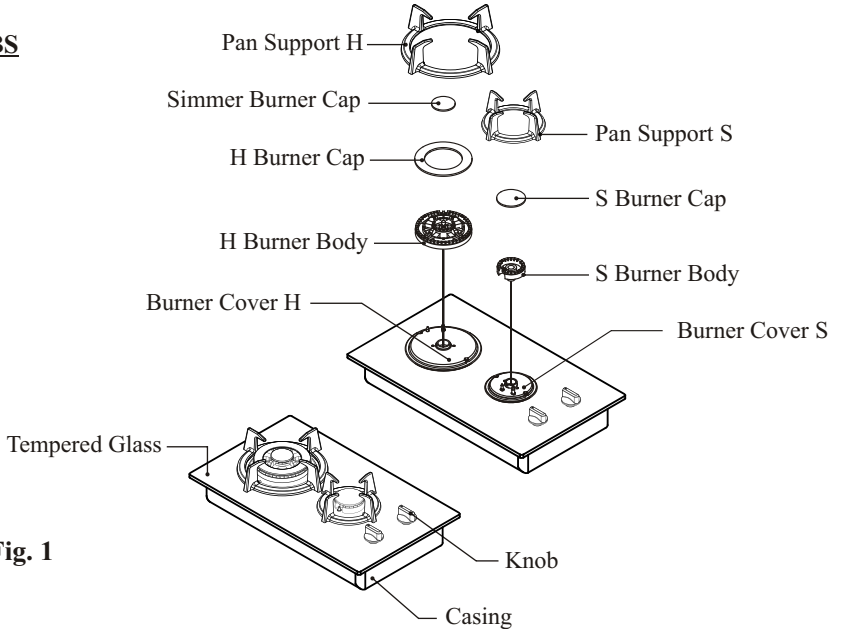

Fig. 1

Features

1. The tempered glass is beautiful and stylish.
2. The enamel pan supports are durable and will not deform, making it stable for your cooking vessels.
3. The continuous ignition device will ensure a 100% ignition rate.
4. Each gas cooker is equipped with a safety valve which will cut off the gas supply automatically if the flame is accidentally extinguished.

Specification

Product		Gas Cooker	
Model		RB-3311S-GBS/RB-3312S-GBS	
Net Weight	RB-3311S-GBS	6.6 kg	
	RB-3312S-GBS	8.0 kg	
Ignition	Continuous Ignition		
	RB-3311S-GBS	"C" Size Battery (1.5V x 1)	
	RB-3312S-GBS	"C" Size Battery (1.5V x 1)	
Overall Dimension	RB-3311S-GBS	310 mm x 520 mm x 130 mm	
	RB-3312S-GBS	310 mm x 520 mm x 130 mm	
Cut out hole size		272 mm x 490 mm	

Diameters of pan which may be used on cooker		
Burners	Min	Max
Main	120 mm	260 mm

* Maximum weight for each burners 20 kg.

Gas Type	Gas Consumption per hour Respective gas consumption (kW)			Total Gas Consumption (kW)	Gas Connecting Tube	
	Center	Front	Back			
RB-3311S-GBS						
L.P.G (28 mbar/ 2.8 kPa)	3.5	-	-	3.5	Ø9.5 mm gas specific rubber hose	
N.G (30 mbar/ 3.0 kPa)	4.0	-	-	4.0		
RB-3312S-GBS						
L.P.G (28 mbar/ 2.8 kPa)	-	1.7	3.5	5.2		
N.G (30 mbar/ 3.0 kPa)	-	1.8	4.0	5.8		

Cut-Out Hole Size

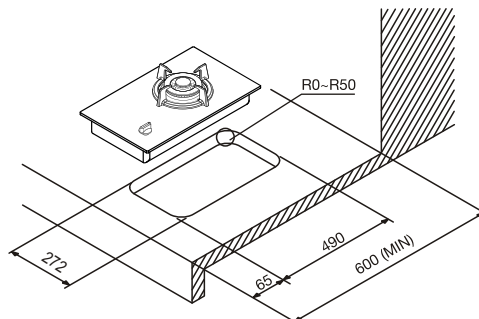

Installation

- Install the gas cooker in well ventilated area and keep away from any combustible or inflammable object i.e. paper, oil, etc.
- If the gas cooker is to be installed near any combustible surrounding i.e. wooden walls, wooden shelves, etc, there should be a distance of more than 15 cm (6 in) away from the surrounding combustible. If the surrounding materials are fireproof, the clearance is not required.
- Place the gas cooker on a stable and level surface.
- This gas cooker is to be used for cooking purposes only. Do not use it to dry towel, clothes or any other materials over it.
- Make sure that the following parts are fitted properly before use.

1. Pan Support

Fit pan support to tempered glass. (Fig. 3)

Fig. 3

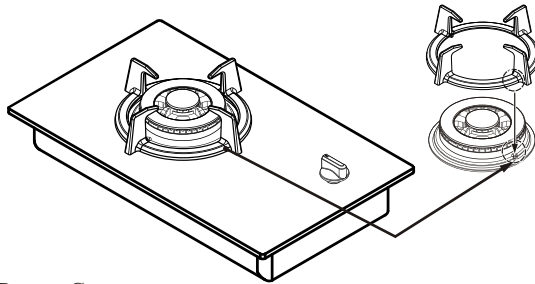

2. Burner Head and Simmer Burner Cap

Fit burner cap and simmer burner cap onto the burner body correctly, without any gap. (Fig. 4)

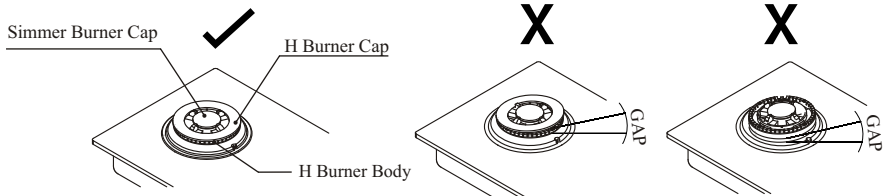

Fig. 4

3. Installation of Gas Hose

- A specific rubber hose for gas cooker must be used.
- The rubber hose must not be bent during installation and must be of an appropriate length (less than 2 m).
- During installation, make sure that the rubber hose does not come into contact with the body of the gas cooker pass through the bottom part of the gas cooker to prevent melting of the hose.
- Place the securing ring over the rubber hose and connect the rubber hose to the coupler below the rear side of the gas cooker till the marked red line. Then secure the rubber hose in position with the securing ring (For LP Gas).

Operating Instruction

Ignition

1. Depress the control knob to about 2 mm, then turn to the left (counter clock-wise) to the “ON” position.
2. When the control knob is being turned for ignition, sparks are generated to ignite the burning device, accompanied by clicking sound.
3. In the event of the burner flames being accidentally extinguished, turn off the burner control and do not attempt to re-ignite the burner for at least 1 min. If the burner has not lit up after 15 seconds, stop operating the gas cooker and open the compartment door and/or wait for at least 1 minute before attempting to ignite the burner again.
4. The flame can be controlled between “MAX” and “MIN” position, please adjust the flame slowly.

Fig. 5

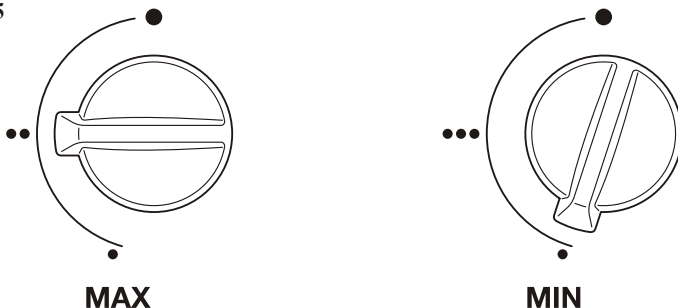

5. Do not clean the top of the sensor with a hard brush, as it may damage the sensor.

Flame Extinguishing

1. After use, turn the control knob right to the “OFF” position and the flame will be extinguished.
2. After extinguishing the flame, do not touch the conductive parts of the cooker as they remain at very high temperatures.
3. There is may be a slight hissing sound after the flames is extinguished.
4. If the gas cooker is not in use, turn off the main gas supply to avoid gas leakage or unnecessary accidents.

How to Handle Safety Device and Change Battery

1. If the flame is extinguish during operation, the Flame Failure Safety Device will automatically cut off the gas within second.
If you notice that the flame has been extinguished, please turn the knob to “OFF” position.
 2. The Safety Sensor is delicate, please do not use stiff brushes or rough cleaning pads when cleaning.
- Aeration is preset at factory during assembly, please do not attempt to adjust it.

- Battery box is located at right front of bottom side (Size C, 1.5V x 1). (Fig. 6)
Open the cabinet door and change the battery.

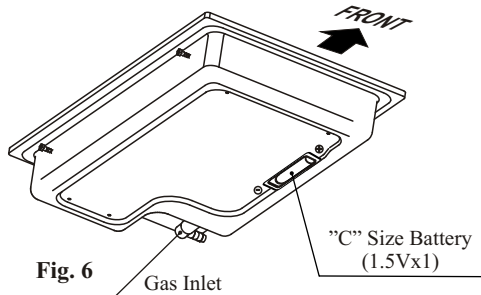

Maintenance

- Wipe the tempered glass with a soft damp cloth and mild detergent.
- Wash the pan support and burner covers in warm water and detergent.

Trouble Shooting Manual for Rinnai RB-3311/3312S-GBS Gas Cooker

FAULT	CAUSE	REMEDY
1. No Ignition	Spark electrode is wet, especially in high humidity season.	Dry the electrode with clean tissue or dry cloth.
2. Flame cannot be held.	Incorrect turning of gas control knob.	Push and turn the gas control knob anti-clockwise until a 'click' sound is heard. Hold for a few seconds until flame is ignited.
3. No main flame.	Gas regulator has been turned off.	Open gas regulator completely.
4. Yellow flame.	Accumulated grease and dirt on the burner.	Wash the burner in warm water with detergent. Leave it to dry, then place it back in the correct position.
5. Unstable flame.	Incorrect location of burner head.	Refit burner head into burner ring.

Attention: when installing the casing

- Adjust screw position as bench cut out size.
- Confirm that four screws are secured firmly into the casing.

Fig. 7

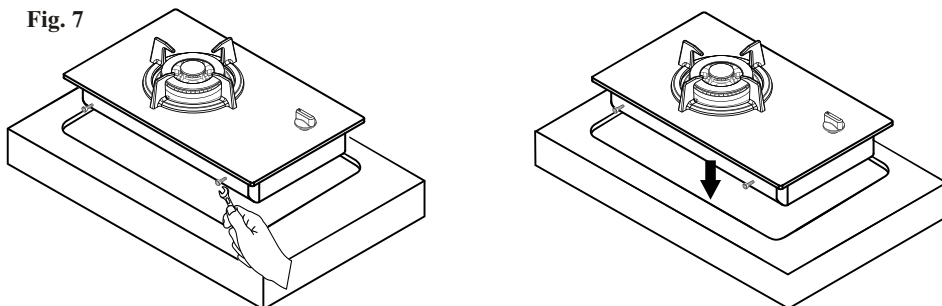

- Installation on the table.

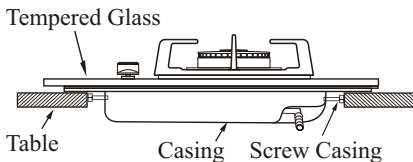

Caution for the tempered glass

- Never use oversized cooking utensils or overload the cooking appliances.



- Do not place the cooker pan over the pan support side as it can cause tumbling.



- Do not remove the pan support and enclose the burner with a wok stand as this will concentrate and deflect the heat onto the gas hob.



- Use only a wok support supplied or recommended by the manufacturer of the appliance.



- Do not place anything, e.g., flame tamer, asbestos mat between pan and pan support as serious damage to appliance may result.

