

Rinnai

COMMERCIAL GAS RICE COOKER



RRA-106/RRA-156







English user manual

INDEX

Notice for safety	1
Name of part	6
How to use	8
Cleaning & Maintenance	16
Check point before complaint	18
Specification	19
How to install	21

Notice for safety

This information is for keeping safety of user and preventing of property damage. Please must read and use rightly.

 Danger	If user doesn't follow instruction, there are dangers that user might lost their lives or wounded.
 Warning	If user doesn't follow instruction, user may lost their lives or wounded.
 Caution	If user doesn't follow instruction, user may wounded or get property damage.
	MUST DO mark.
	General prohibition mark – it emphasize the things not to do.
	Earth display for electric shock prevention.

Danger

If it seems like gas is leaking

- If you suspect gas leakage, do not turn on the light or electric appliance or plug and do not use telephone. It may cause explosion accident by electricity.

In this case, follow below step.

1. Stop using and close the intermediate gas valve.
2. Open the window to ventilate.
3. Contact to service center.

In this time, do not use the cell-phone or telephone nearby, use the telephone outside.

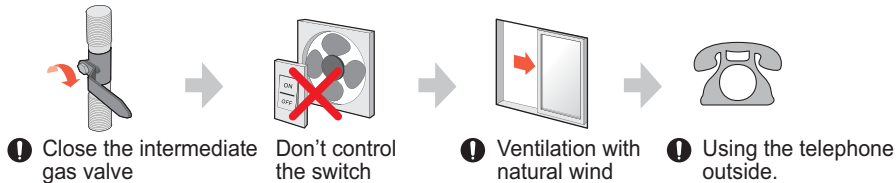

- When you notice earthquake, fire, abnormal combustion, abnormal sound and smell during using, Stop using immediately, close the intermediate gas valve and do the ventilation.

Ventilate by opening the windows.

- Do not spray water. (Especially during cleaning)
If water passes throughout electronic part or burner part, it is a direct cause of breakdown fire or injury.
Do not spray water never.

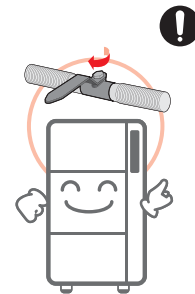

Warning

- **Do not place inflammable nearby.**
It may be a cause of breakdown and fire by overheating.
- **Do not touch the product, during using and until cooling down after using.**
Do not let children get near especially, the product is very hot, may get burnt.
- **Do not leave turning on.**
Due to heat with high calorie burner, user has to be careful during using.
- **Do not never disassemble, repair or convert except our(rinnai)service engineer.**
If you disassemble, repair or convert discretionally, it influence to production safety seriously.
When you think that it is breakdown, please reference user manual or contact our service center.
- **This product is only for rice cooking. Do not use for other purposes.**
It may cause fire or product damage.
- **Do not block the exhaust pipe.**
Do no bloc the exhaust pipe with dishcloth or such like that.
It may cause breakdown or fire by imperfect combustion.
- **Do not use where can be sloshed water never.**
If water passes throughout power supply part, it may cause of malfunction, electric shock or product damage.
Please take care not to drop the water to burner.
If water drops, it may cause short circuit or ignition-fail.
- **Do not let the gas pipe pass the underside, upper side of product or around exhaust pipe.**
By melting gas hose with high temperature, there is a risk of gas leakage
- **Do not put something or give big shock to part of heat sensor which is attached inside body of product.**
The heat sensor could be damaged.

- **Use specified gas only.**
Check whether the using gas is same with name plate. If the gas is not same, it may cause not-operating, product damage or fire by abnormal combustion or overheat. The name plate is on the right side of product.
(If you don't know about using gas, please contact our service center)
When you move, check the using gas and name plate is same.
- **Make sure to check an earth at electric wiring work**
Check whether the using power is same with name plate.
Use an earth-socket.
Regarding electric wiring, request to experts for electric equipment.

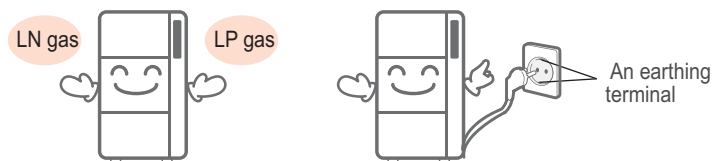

Caution

- **Shorten the gas piping and power code as short as possible, do not extend.**
Especially, do not let the gas pipe and power code pass the underside, upper side of product or around exhaust pipe.
By melting gas hose or power code with high temperature, it may cause fire by short circle or gas leakage.
- **Do not use the door open.**
By malfunctioning of sensor, it may cause poor rice cooking or product damage.
- **Do not use in windy place (in front of window or fan)**
It may cause damage of inner product and malfunctioning.

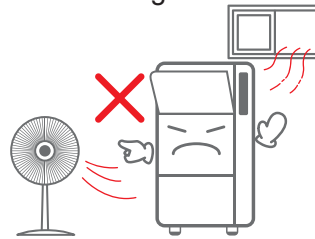

- **Ventilate often during using.**
The waste gas and oxygen deficiency cause carbon monoxide poisoning.
- **Install the products where is horizontal and securely fixed.**
Especially, install the product in well- ventilated place.
If you use insecure place such as in the car or ship, it may cause fire or burns.
- **Check the open-close condition of intermediate gas valve.**
Check the valve-open before using, and valve-close after using.
- **When you igniting, check the ignition condition by ignition checking lamp () at the 30cm away from the product.**
Please re-ignite after leaked gas losing(Around 5 sec) when you failed to ignite in 2-3 times In case of day very humid(rainy season), it could be failed to ignite due to moisture in ignition part.
Also, in case that rice-cooker hasn't been used long time, Ignition could be failed due to air in gas pipe.
Please ignite repeatedly at this time.
- **Take care not to be transformed the lid of rice pot.**
In unavoidably situation, load up under 4 layer.
- **Close the door slowly and right.**
If the door does not close right, the heat in combustor is leak, it may cause breakdown such as transform, discolor and there is danger of burns.
- **Take care that the power code not to be touched back side of product like exhaust pipe.**
By melting power code with high temperature of exhaust pipe, it may cause breakdown and fire by short circle.

Especially, attention these

- **Check the open-close condition of intermediate gas valve.** Check the valve-open before using, and valve-close after using. Open the intermediate gas valve before starting daily work, and must close the valve at day's end.

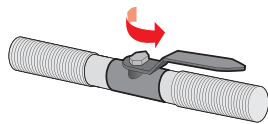

Valve-opened(before using)

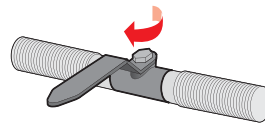

Valve-closed(after using)

- **Check the piping work is done to meet the product standard.** Especially, when several product are installed at the same time, if the volume of gas pipe is not enough, abnormal combustion, performance degradation and sympathetic sound (pi- sound) can be caused.

- **Deflate the gas pipe at first use or reuse after long-term non use.** Before deflate, ignited poorly with noise. Repeat turning the ignition on, the flame become stable.

- **Make sure the power cord does not touch the exhaust pipe.** The exhaust pipe generate heat. If the power cord touch the exhaust pipe, there is danger of fire by melting with high temperature.

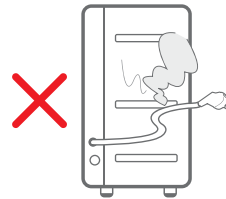

- **Make sure use cold water with room temperature.** If you use warm water, the heat sensor notices high temperature. It may cause half-cooked rice. So, use the room temperature water.

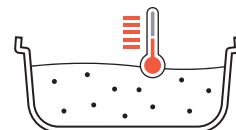

- **Do not soak the rice long time.**

The suitable time is 30 min. for summer, 1hour for winter.

If rice is soaked long time, rice is crashed easily, the crashed rice sink under the rice pot, And make the layer to disturb the heat distribution. Especially, the rice crashed easily when you wash the rice after soaking or wash powerfully Rinse well not to remain crashed rice after washing the rice.

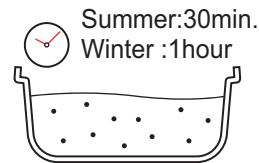

- **Clean and remove the water on bottom of rice pot before rice cooking.**

The bottom of rice pot touch the heat sensor which sense the temperature automatically. If the bottom of pot is dirty, the heat sensor can not sense the exact temperature.

And also, If you cook the rice when the heat sensor still hot, it causes half-co oked rice same as when cooking with hot water. Use after cooling down.

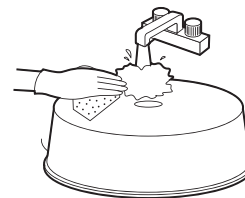

If you want cook the rice consecutively....

- Clean the bottom of rice pot, and remove the water completely
- Clean up water and foreign substance on the top of heat sensor with clean dishcloth Especially, use after the heat sensor part cooling down completely.

- **Do not never wash out heat sensor part.** It causes breakdown and fire.

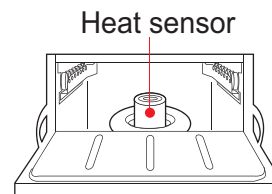

- **Do not never spray water to product. (especially during cleaning)**

If water passes throughout product, main parts such as main p.c.b are damaged, and causes fire by short circuit, When you clean up , use the soft dishcloth with neutral detergent.

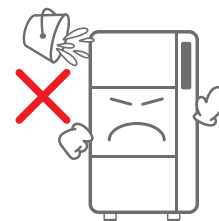

Name of part

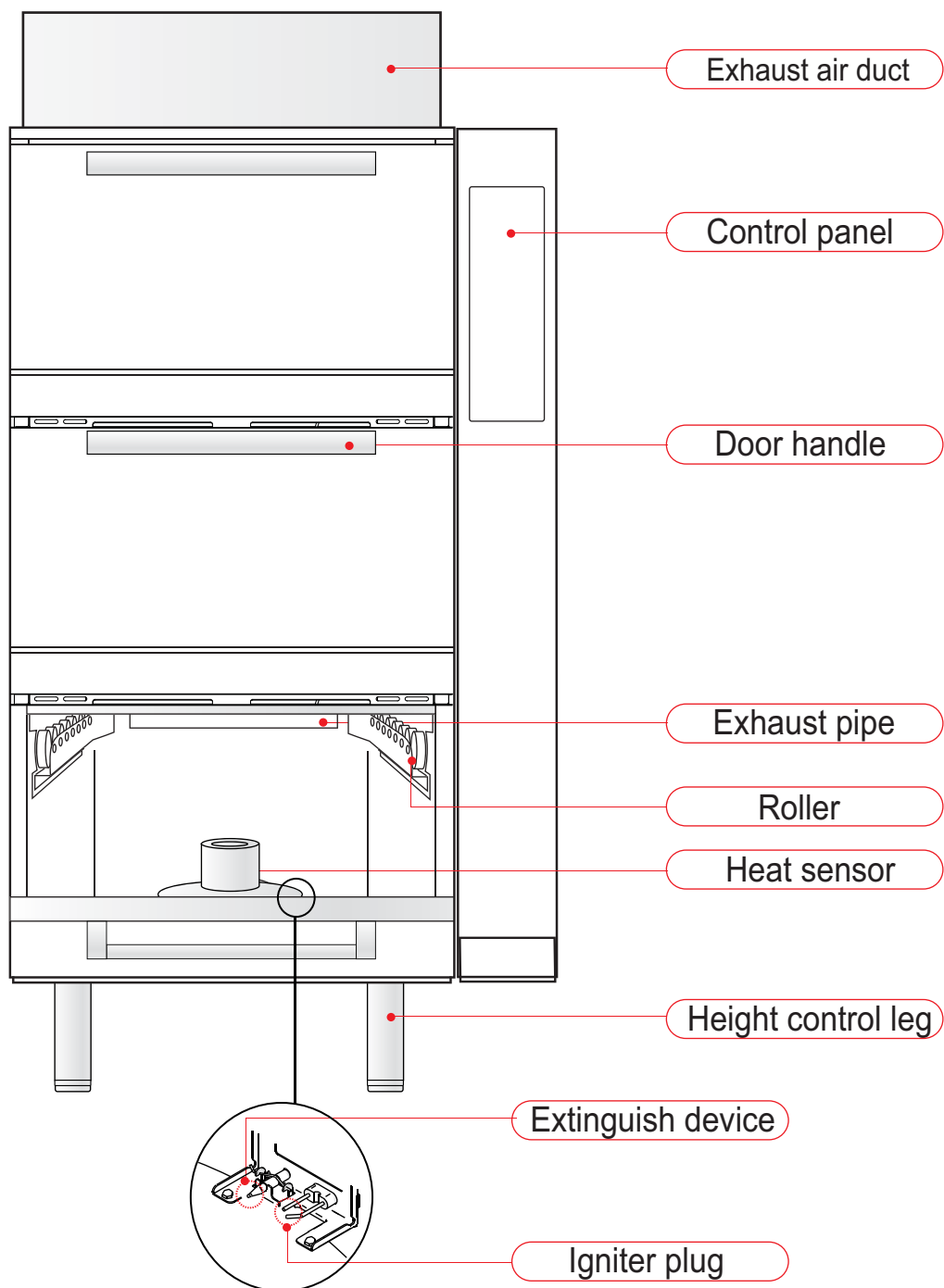

The control panel

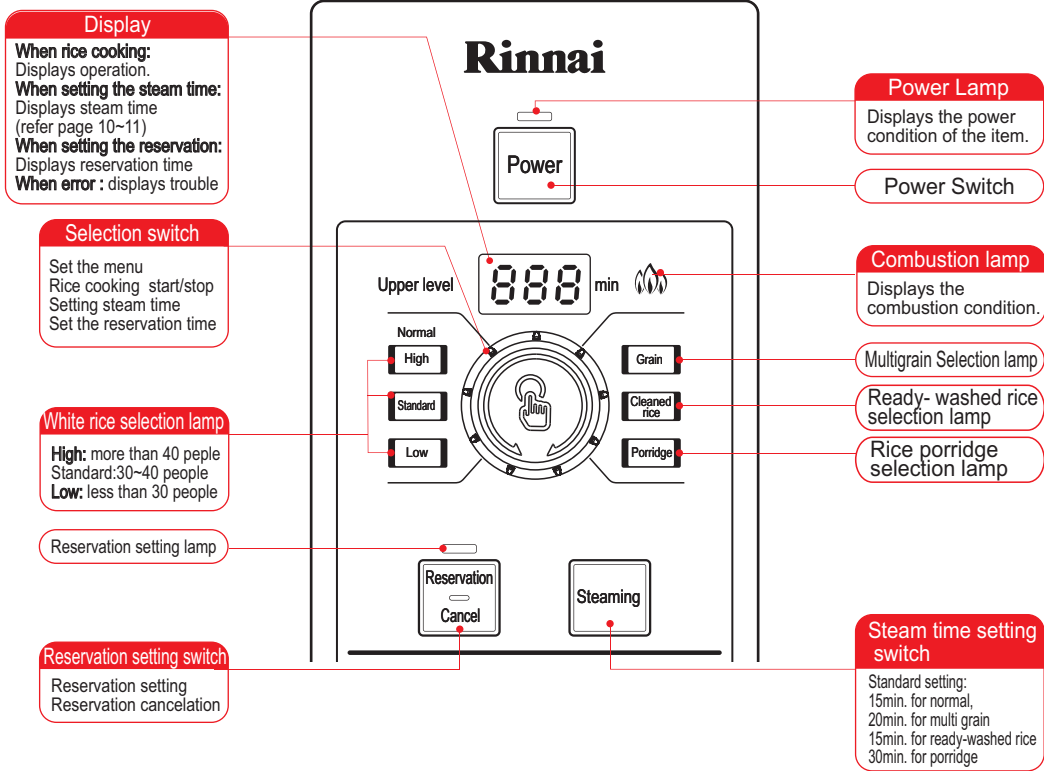

Attachments

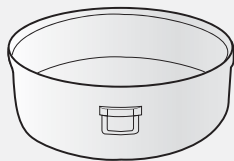

Pot

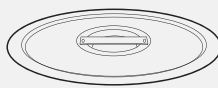

Rid

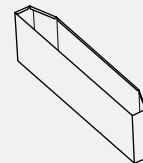

Exhaust air duct

Quantity of attachments by model

Attachments	RRA-106	RRA-156
Pot	2pcs	3pcs
Rid	2pcs	3pcs
Exhaust air duct	1pcs	1pcs

How to use (right way to use)

heck the followings before using.

Check one more time.

1. Is the intermediate gas valve opened?
2. Did you checked the power connection?
3. Is there an earth on the socket?
4. Have you done the air-bleed?

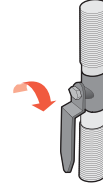

1 Measuring rice

Use the carved gradation on the pot.

Use the scale to measure the rice correctly.

The finish time can be different by kind of rice, water temperature, water quantity.

A conversion table of rice quantity

Serving	Rice (raw rice)	Gradation (soaked rice)	Finish time (including carry over cooking time - 15min.)	Choose the menu
50	About 7.5kg	물(인분) 50 물(인분) 50	About 36 min	High
40	About 6.0kg	50 40 30 물(인분) 50 물(인분) 40 물(인분) 30	About 33 min	Standard
30	About 4.5kg	물(인분) 30	About 32 min	
20	About 3.0kg	No gradation on the pot	About 32 min	Low



Caution

- The maximum serving is for 50 people. Minimum is for 30 people . (ready-washed rice is max. 40person.)
- When you cook rice for 30 people or less (rice about 4.5kg), rice can stick at the bottom.
- When you cook rice for 50 people or more(rice about 7.5kg), rice can be half-cooked.

Rice porridge

- The rice quantity for porridge is 1.0 kg, and 1,5kg
- Measuring line inside of pot is an indicator of water level in normal porridge condition. you can adjust water lever according to porridge statue.

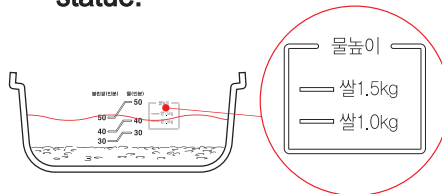

Water quantity	Watery porridge	Normal porridge	Thick porridge
1.0kg	Water: 10times of rice q'ty	Water: Up to gradation on inside the pot.	Water: 6times of rice q'ty
1.5kg	Unable cooking		

2 Washing the rice.



If you wash the rice after soaking, the rice is crashed easily because the water through something the rice.

Make sure wash before soaking the rice.

Rinse several time (3~4times) until clear water is coming.

If crashed rice powder is remained on the rice, the crashed power sink on bottom, and disturb the heat distribution. it is direct cause of poor cooking.

When you wash the rice, do not apply enough force.

Wash slowly and softly and rinse well.

3 Soaking the rice.



Soaking the rice 30minutes in summer, 1hour in winter.

If rice is soaked long time, rice is crashed easily, and cause three-layered cooked rice with each layer having a different degree of steaming and cooking. Soak the rice after washing.

The soaking time of multigrain rice same as rice.

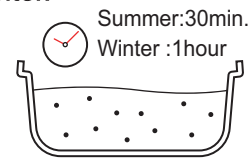

4 About selection and storage of rice.



Do not use the expiration date passed rice and use rice in opened package first in short time

Because long-stored rice is dried up, crashed easily and need long soaking time

These are causes of poor- cooking.

Store the rice in a cool dry place.

5 Setting water and rice q'ty.



Put the soaked rice and cold water adjusting gradation inside the pot.

Ex) when you cook 30 serving, set the soaked rice to "30" gradation and adjust the water to "30" gradation.

- Adjust the water considering kind of rice (mixed grains, white rice), storage period (newly harvested rice, long-stored rice)

- The gradation inside the pot is general standard, adjust according to your preference.

- Avoid the maximum or minimum q'ty cooking, it may cause underdone or burnt rice.

- use the gradation in the "○" when you cook porridge.

Weight the rice 1kg or 1.5kg using scale, and pour the water until the gradation.

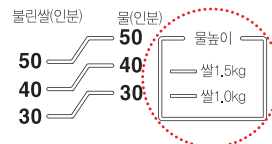

6 Cooking with ready-washed rice.



When cooking with ready-washed rice, pure water more than gradation of rice pot.

Water gradation	Water gradation	Water q'ty
Serving for 40 person	Add 500ml of water more than the gradation "40"	1.4 times of rice.
Serving for 30 person	Add 380ml of water more than the gradation "30"	

Ex) when you cook 40 serving, set the water to 40 gradation and add about 500ml of water.
- Control the water q'ty as kind of rice, storage period and rice condition.



Caution

- Have a soaking time same as white rice.
- The ready-washed rice is not needed to wash, but rinse rightly at least once. If the rice flour sink to bottom without rinse, it may cause poor-cooking.
- The maximum cooking q'ty of ready-washed rice is 40 servings(6kg)

7 Install the rice pot.



Open the door and push the rice pot covered lid with rice and water into the fire chamberlf.

If there is water on the bottom of pot, it may cause poor-cooking, before install the rice pot, remove water on the bottom of pot.

The handle of pot should be facing forward.

Push the pot to the end then close the door slowly.

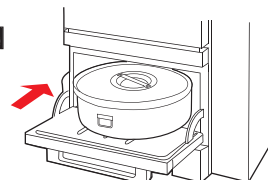

How to use

1 Turn on the power

Press the power button and check the light on power lamp With displaying “---”

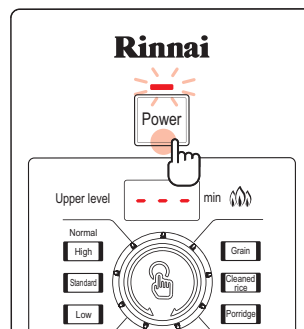

2 Set the time of menu and steaming

Cooking

Select the deck to cook and choose menu. Just dial the jog shuttle with twinkling lamp. Menu will be kept on next cooking unless you don't change

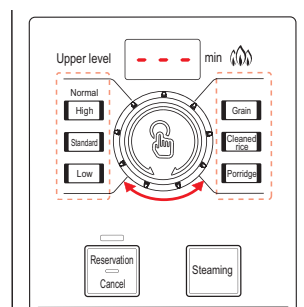

Setting up steaming time

Press the Steaming button and dial the jog to find steaming time.

If you don't select the mode, Machine returns previous mode.

General steaming time is 15min

Grains 20min, Porridge 30min

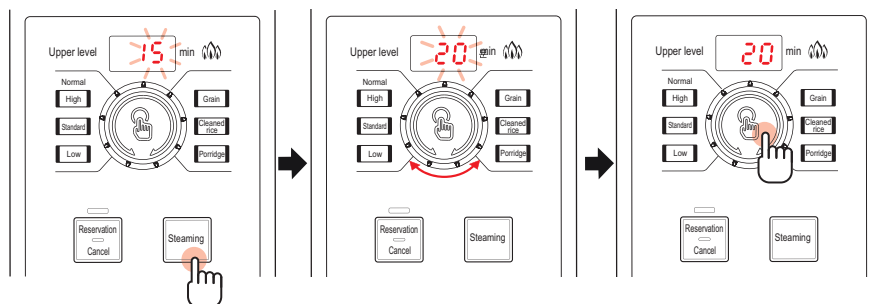

3 Cooking

Press the Jog dial shortly (about 1sec)
Cooking process will be started automatically
And Combustion lamp turning on and the
square mark will rotate

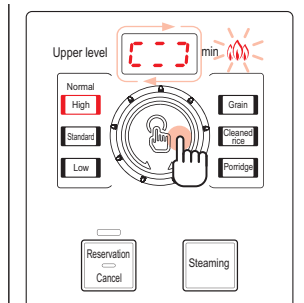

Caution

Please do not open during cooking process to prevent half-cooked rice

4 Steaming

When cooking is over, the buzzer will sound and cooking lamp will
go off to start steaming process.

You can check steaming time in display lamp you set.

The buzzer will sound after steaming process

- Once the cooking starts, the steam time cannot be hanged.

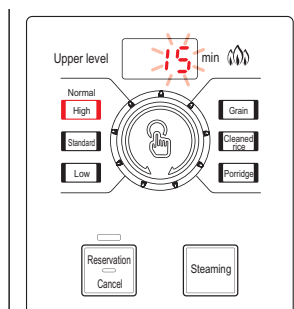

Steam setting

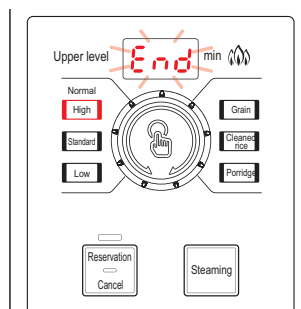

Cooking setting

5 Completion

Pull the kettle out after buzzer alarm It means
all process completed including seaming.

At this time, the pot is very hot so always use
gloves Finally, press the selection button to be
off buzzer and display lamp and close middle valve.

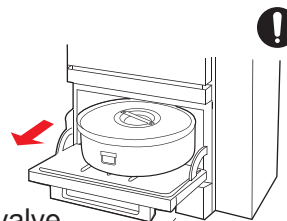



※ When “End” mark is on the screen, user can't cook rice but also can't change any setting Please turn intermediate valve off



Caution

- **Do not load too much weight on the product door.**
Do not put the pot filled with soaked rice and water or the pot after the cooking on the door.
It may cause damage to the product

Continuous rice cooking

- If you are cooking continuously, wash inside the pot cleanly and use it after the heat sensor inside the pot gets completely cool. If you cooking with dregs inside the pot or when heat sensing part inside the pot is not completely cool, bad cooking may occur.
- Put soaked rice and water into the cooled pot then push the pot into the level you want to cook then close the door and always wait for 5min then start the next cooking.



“Close the door and wait 5 minutes to start”

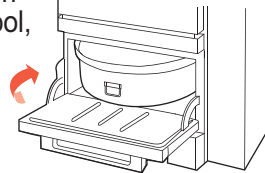

Reservation cooking

1 Select the level you want to cook among [top, middle, low] And Menu, Steaming time.

2 Put the kettle into level to start cooking
Rice should be washed by clean water

3 Press reservation button shortly (about 1sec)

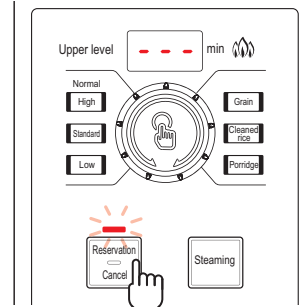

4 Set reservation time to start

Control jog dial to set time to use.

- Dial to set hour and press dial.
- Dial to set minute and press dial.

Ex) As below picture, "1:20" means cooking starts automatically after 1hour 20minute.

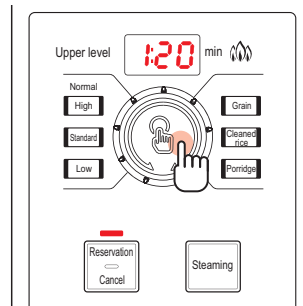
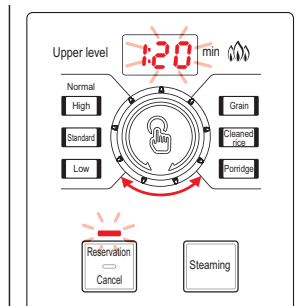

Caution

When you put rice in the water for long period in summer or high temperature inside the kitchen, the rice may get spoiled and also rice can be damaged and it may cause bad cooking.

5 Set reservation time to start.

If you want to cancel the reservation, push the pertinent level switch for 2~3secs. Lamp will go off and the reservation will be cancelled.

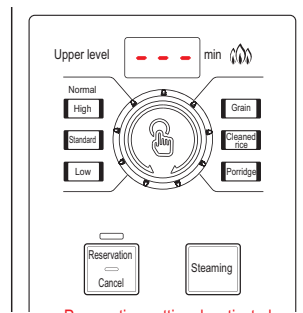
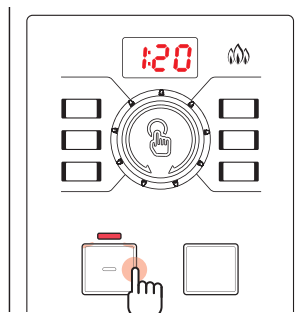

Reservation setting deactivated

In case of power cut

- During a power cut, the operation will stop. At this time, if electricity comes back within 7min it will automatically go on with the process before the power cut.

- If electricity comes back after 7min, it does not return to its original course but error [00] will be displayed on the operation panel and the buzzer will sound. In this case, push start/stop switch to stop the error display then push the power switch to turn off power and you will have to start the cooking from the beginning.

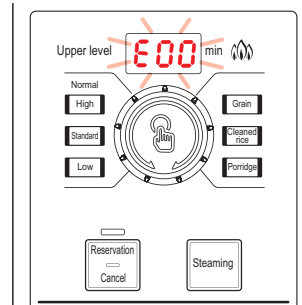

- In state when 7min passed after power cut and if you start over the cooking without changing the contents inside the pot, scorch on bottom of the pot or early extinguishing may occur.

Cleaning and maintenance

Warning

- **Do not hose or spray on the product.**
It may cause fire accident or broken by shortcircuit.
- **Do not use highly inflammables like thinner, Benzene to clean.**
It may cause fire accident or broken by shortcircuit.
- **Please use your hand only to operate the product to keep your machine in good condition.**

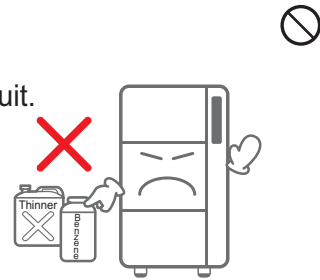



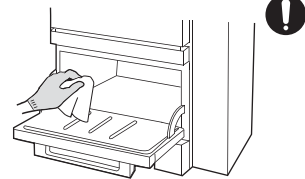





- **Please use gloves when you need to clean inside the product.**
It protects your hand from high temperature or sharp edges inside.



Caution

- **Make sure that Pull the power plug out when you check, clean, maintain the product.**
- **You should check inside the product after cleaning, maintaining whether the tools or cleaning equipment are inside or not.**

Possible to use	Impossible to use
 Soft cloth	 Nylon brush
 sponge	 Metal brush
 neutral detergent	 Cooking Oil
	 Acide, Alkali detergent
	 Thinner, Benzene
	 Polisher



- **Use Soft cloth to clean the product often.**
Metal or nylon brush can damage on the surface of the product.
- **After cooking, Use neutral detergent for cleaning and get rid of moisture on the product.**
Be careful to keep water off the product when you clean.
- **Keep the kettle dry cause aluminum kettle can be easily discolored by watered for long time.**
- **Especially Operation panel and power trans should be protected from the water drastically.**
Keep the kettle dry cause aluminum kettle can be easily discolored by watered for long time.
- **If there are lots of food waste inside the product, Clean with open The door as below picture.**

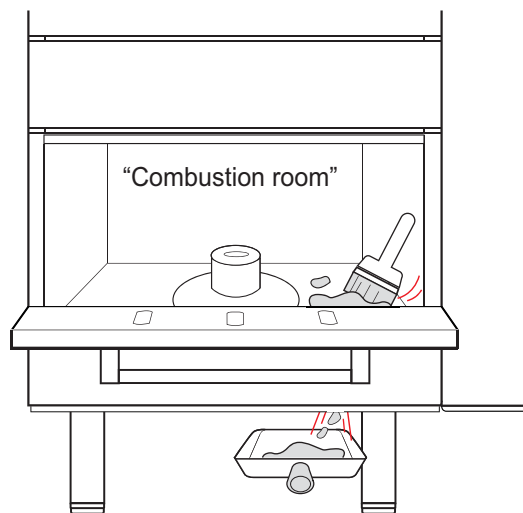

- **Check and get rid of food waste hanging from the ceiling inside.**
Food waste can be dropped on the rice during cooking.



- **Please Keep the burner holes clean from the food waste always.**
- **Check the ignitor and safety device are contaminated or not.**
(P6 picture)

Check list before service call

- This product has self monitoring function which can alarm by buzzer sound with error code on the displaying panel when it has problem.
- If it keeps going on after repower process. Please contact service agent or dealer.

Error codes	Condition	Measure
E 00	Returning electric power after 7minutes of black out.	Press jog dial and retry with new rice.
E 11	No ignition or problem.	Press the jog dial and check Middle valve and gas supply. IF no problem, Jus start again from thebegining
E 12	Unexpected stop during cooking.	
E 24, E 28, E 31, E 52, E 71, E 72	Main PCB problem	Please contact to the Authorized Service stations

	Condition	Check list
Product working	No signals on display panel	- Check the power plug in - Is main power black out or not? - Is the power button on?
	No Ignition	- Does it open middle valve? - Check it LP gas tank empty
	Lamp on operation panel blinking	- Refer to the error codes
Cooking	Boiling over	- Too much water or rice
Condition of Rice	Half cooked Too soft or hard	- Did it return from black out? - Are rice and water amount proper? - Check the soaking time - Check steaming time - Is there any dirt on the heat sensor - Or bottom of the kettle?

Specification

Specification

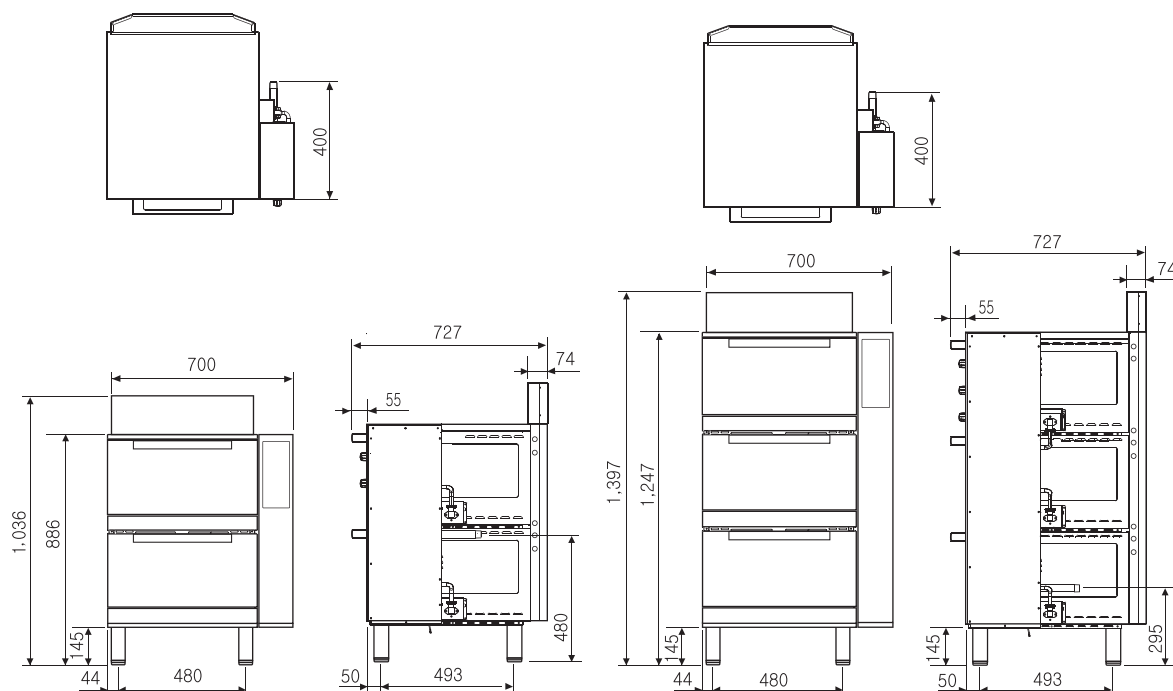

		RRA-106			RRA-156				
Size (W×D ×H)		700×727×1,036			700×727×1,397				
Weight/Box included (kg)		85			129				
Connector	Gas	3/4" (20A)							
	Electric	220~240V / 50, 60Hz							
Safety device		Extinguish device, Extinguish timer							
Power consumption	VOLTAGE	220 V	230 V	240 V	220 V	230 V	240 V		
	LP	34 W	34 W	38 W	50 W	50 W	52 W		
	LN	29 W	29 W	31 W	41 W	41 W	45 W		
	TG	25 W	35 W	-	35 W	50 W	-		
Max/Min Cooking capacity		20~100 people(3-15kg)			20~150 people(3-22.5kg)				
Accessory		Kettle 2ea, Lid 2ea, Duct 1ea			Kettle 3ea, Lid 3ea, Duct 1ea				
Gas consumption	LP	kW	11.30	11.30	22.10	11.30	11.30	11.30	33.7
		kg/h	0.80	0.80	1.58	0.80	0.80	0.80	2.42
	LN	kW	11.30	11.30	22.10	11.30	11.30	11.30	33.7
		kcal/h	9,700	9,700	19,000	9,700	9,700	9,700	29,000
	TG	kW	11.30	11.30	22.10	11.30	11.30	11.30	33.7
		kcal/h	9,700	9,700	19,000	9,700	9,700	9,700	29,000

Installation method

Must read this manual and make sure that all contents before installation of the product.



Caution

- Please confirm all contents before installation.
- Must be sure to connect the gas displayed on the name table of the product.
Request authorized engineer or Rinnai agent when you connect and install the product.
Please check middle valve condition before use.

1 When installing the product, make sure to keep distance from inflammables

Ceiling or shelf as inflammable : Over 70cm

Side wall as wooden material : Over 20cm

Back side wall as wooden material : Over 30cm

- When installing heat proof board contacted inflammable wall between the product, It can be dangerous of fire accident to use long time.
- Heat proof board should be manufactured and installed as proper type for the place.(We don't supply heat proof board)

Keep away over 100cm when if exist fire alarm at the place to install.

Must install air ventilator at the place.

This product discharge a lot of combustion gas, Must install exhaust gas hood.

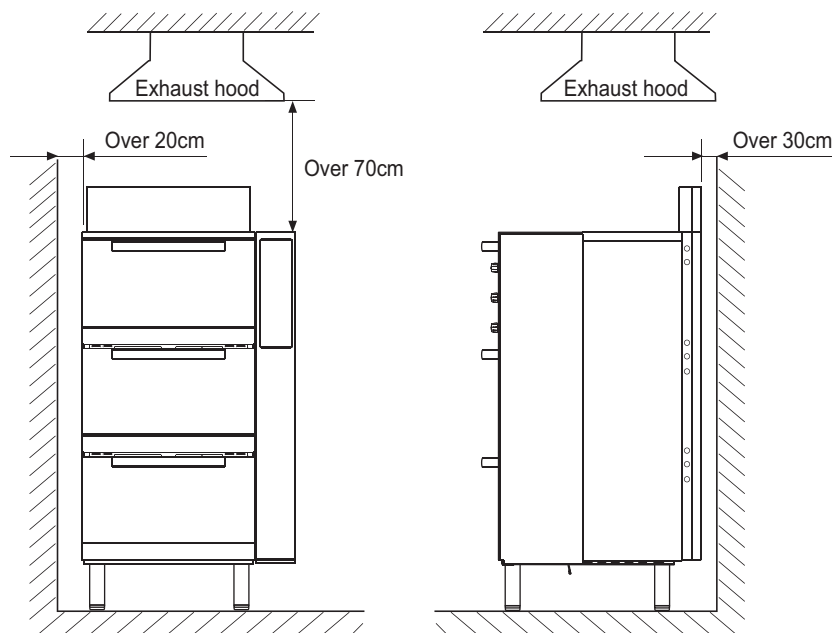

Heat proof board not installed

2 When installing over 2 items, maintain the distance between the 2 products over 30cm.



Space for service performance.

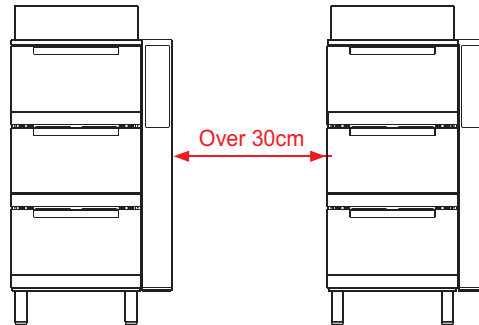

3 Keep flat condition at bottom part.



Adjust the height by leg of the product.

Height adjustment

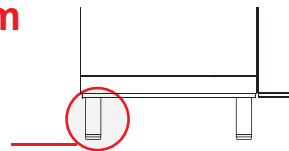

- **Must get rid of air in the gas pipe when first use or not used long time.**
It may happen bad ignition or noisy and lifting flame before air clearance.
Repeat ignition few times for clear bad ignition or lifting flame.



- **Make sure that electrical wire installation before use.**
Check proper voltage and Herz of the product and your place.
We strongly recommend to install by authorized person with licence or Rinnai agent.
Must ground the product.
- **It should be installed circuit breaker at distributing board.**
(Capacity of circuit breaker should be over 30mA)

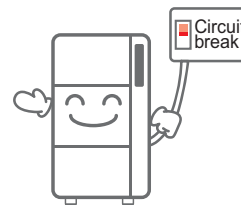

- **Be sure that power cord must not contact to exhaust part on the back side.**
Exhaust part is extremely dangerous to contact power cord by high temperature can occur fire accident.

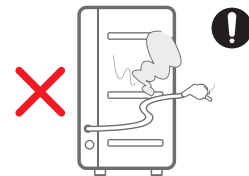

4 Install exhaust air duct

Assemble exhaust air duct to exhaust hole attached back side of product and fix it with 2pcs of bolt(M4) included.
- fixing bolt is attached to side of exhaust air duct.

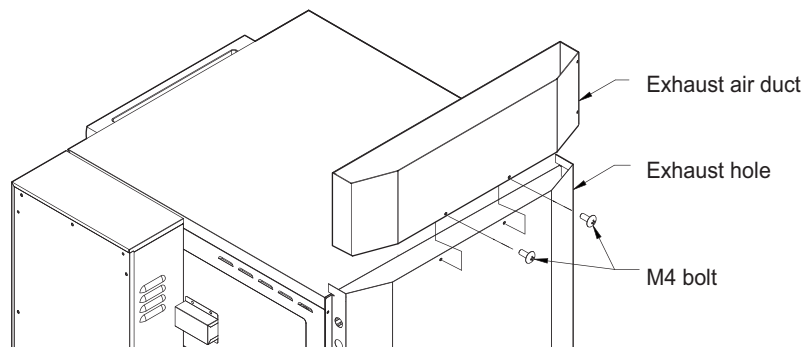

MEMO

MEMO

MEMO

Rinnai

ver.150203

