

Rinnai

Continuous flow and temperature control instantaneous gas water heater

Operation and installation manual

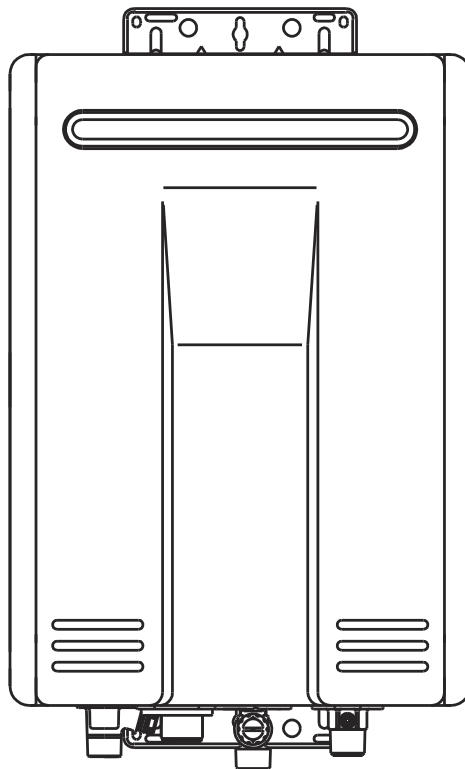

REU-A1620WD-GEN – *Infinity 16 external - 16e*

REU-A2626WD-GEN – *Infinity 26 external - 26e*

This appliance must be installed in accordance with:

- Manufacturer's installation instructions;
- National laws, local regulations and municipal building codes.

This appliance may only be installed by a registered Gas installer.

Read these operation and installation manual carefully before using the appliance and retain them for future reference

This appliance shall only be installed in an outside location

INTRODUCTION

Rinnai, constantly striving to improve the products, reserves the right to modify the details given in this documentation at any time and without notice.

From the time this manual is printed and attached to the product, to the time the product is purchased and installed, the instructions and warnings may have changed: for Your interest and Your protection we recommend that You follow the instructions and warnings reported on the most recent version of the manual which is always available at the authorised Rinnai service company.

Rinnai disclaims any liability due to printing or transcription errors and reserves the right to update and change any technical and commercial lists without prior notice.

Dear Customer, our compliments for having chosen a Rinnai top-quality product, able to assure well-being and safety for a long period of time. As a Rinnai Customer you can also count on a qualified after-sales service to guarantee a constant efficiency of Your appliance.

The following pages are very important and contain useful instructions and suggestions on the correct use of Your appliance.

Don't hesitate to contact immediately Your local Rinnai service to provide You a first commissioning of the product and to check the correct installation: a qualified technician will verify the correct functioning of the product, adjust any parameter if required and teach You the correct use of it.

GENERAL ADVISE

Rinnai products are provided with a packaging suitable for transport. The product must be stored in dry environments and protected from bad weather.

This manual is part of the product and must be left to the new user in the case of property change of the appliance. The manual must be kept in a safe place and carefully consulted as all warnings provide important safety instruction for the installation, the use and the maintenance.

This manual contains technical information on how to install the product: for any issue related to the installation, comply with the national and local laws in force and technical standards. According to legislation in force, the systems must be designed by qualified technicians. Installation and maintenance must be performed in compliance with the regulation in force, according to the manufacturer's instructions and by qualified personnel.

An improper installation or assembly of the appliance (components, accessories, kits, etc.) can cause unexpected problems to people, animals and property.

The product must be destined to the use for which it is designed for. Any other use will be considered as improper and therefore potentially dangerous.

In case of any errors in the installation, the use or the maintenance due to non compliance of the laws in force, Standards or manufacturer's instructions, the manufacturer is excluded from any contractual and extracontractual liability for any damages and the appliance warranty is invalidated.

The user may not install or adjust the appliance in any way that requires the removal of the front cover of the unit: to remove the front cover of the unit you must be certified competent to do so.

IMPORTANT

According to local laws in force, heating and hot water systems are subject to regular maintenance and regular checking of the heating performance. To comply with these obligations we invite You to contact the authorised Rinnai service company.

For further information on regulations related to the installation of the water heater or to find out Your closest the authorised Rinnai service company.

WARRANTY

Dear Customer,

Our compliments for having chosen a Rinnai product.

The standard Rinnai warranty does not affect the terms of the legal warranty on customer's good and relates to Rinnai products purchased.

WHAT IS COVERED?

The warranty covers any defects in materials or workmanship when the product is installed and operated according to Rinnai installation instructions, subject to the terms within this limited warranty document. This warranty applies only to products that are installed by a registered gas engineer. Improper installation may void the warranty. This warranty extends to the original purchaser and subsequent owners, but only while the product remains at the site of the original installation. The warranty only extends through the first installation of the product and terminates if the product is moved or reinstalled at a new location.

WHAT WILL RINNAI DO?

Rinnai will repair or replace the product or any part or component that is defective in materials or workmanship, except as set forth below:

- all repairs must be performed using genuine Rinnai parts.
- all repairs or replacements must be performed by a registered gas engineer.

Replacement of the entire product or replacement of any parts may only be authorised by Rinnai.

Rinnai does not authorise any person or company to assume for it any obligation or liability in connection with the replacement of a product or heat exchanger. If Rinnai determines that repair of a product is not possible, Rinnai will replace the product with a comparable product, at Rinnai's discretion. If a component or product returned to Rinnai is found to be free of defects in material or workmanship, or damaged by improper installation the warranty claim may be denied.

HOW DO I GET SERVICE?

Contact the authorised Rinnai service company.

Proof of date of purchase is required to obtain warranty service. You can show proof of purchase with a dated invoice.

WHAT IS NOT COVERED?

This warranty does not cover any failures or operating difficulties due to accident, abuse, misuse, alteration, misapplication, acts of God, improper installation, improper maintenance or service, inadequate water quality, scale buildup, freeze damage or for any other causes other than defects in materials or workmanship. This warranty does not apply to any product whose serial number or manufacture date has been defaced.

Rinnai is not liable for any special, incidental, indirect or consequential damages that may arise, including damage to person or property, loss of use, failure to install drain pan under unit, or inconvenience.

CONTENTS

1. USER'S INSTRUCTIONS	5
1.1 FEATURES AND BENEFITS	6
1.2 IMPORTANT SAFETY INFORMATION.....	7
1.2.1 OPERATIONAL SAFETY INFORMATION	8
1.3 WATER TEMPERATURE CONTROL	10
1.3.1 MAXIMUM DELIVERY TEMPERATURES.....	10
1.3.2 OPERATION WITHOUT WATER CONTROLLERS	10
1.3.3 RINNAI WATER CONTROLLERS	10
1.3.4 WATER CONTROLLER COMBINATIONS & CONFIGURATIONS.....	11
1.3.5 UNIVERSAL WATER CONTROLLER (MC-601) OPERATION.....	12
1.4 TROUBLE SHOOTING	14
1.4.1 ERROR CODES	14
1.4.2 TROUBLESHOOTING WITHOUT WATER CONTROLLERS.....	16
1.4.3 SERVICE	16
2. INSTALLER'S INSTRUCTIONS	17
2.1 INSTALLATION WARNINGS.....	18
2.1.1 APPLIANCE LOCATION	18
2.2 UNPACKING THE WATER HEATER	19
2.3 DIMENSION	19
2.4 INSTALLATION	20
2.4.1 SELECTING A LOCATION.....	20
2.4.2 WATER CONNECTION	22
2.4.3 GAS CONNECTION	22
2.4.4 ELECTRICAL CONNECTION	23
2.4.5 CONTROL BOARD DIPSWITCH SETTING	23
2.5 WATER CONTROL	24
2.5.1 GENERAL INFORMATION	24
2.5.2 UNIVERSAL WATER CONTROLLER (MC-601) INSTALLATION	26
2.6 COMMISSIONING	27
2.7 TECHNICAL DATA	28

1. USER'S INSTRUCTIONS

The following section provides instructions for proper use of the product. This section is intended for the use by qualified technical personnel and end users.

1.1 FEATURES AND BENEFITS

Congratulations on purchasing the latest technology temperature controlled Rinnai continuous flow water heating system.

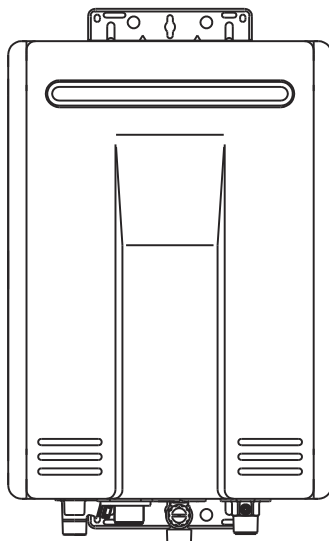

The Rinnai continuous flow water heater products **NEVER RUN OUT** of hot water. Whilst electricity, water and gas supplies are connected, hot water is available whenever hot water taps are open.

Built into the main micro-processor is the facility to **LIMIT THE MAXIMUM TEMPERATURE** of the hot water supplied. The water temperature may be limited to various values. This is particularly useful when the hot water unit is installed where young children or the infirm may be using the hot water.

The Rinnai continuous flow water heater products are fan-assisted (power flued) appliances. This makes them **COMPACT**, saving both floor and wall space.

The temperature of hot water is **CONSTANTLY MONITORED** by a **BUILT-IN SENSOR**. If the temperature of the hot water rises to more than 3°C above the selected temperature the burner is turned OFF and only turned ON again when the temperature falls below the selected temperature.

The burner lights automatically when the hot water tap is opened, and goes out when the tap is closed. **IGNITION IS ELECTRONIC**, so there is no pilot light. When the hot water tap is off, no gas is used.

'Deluxe' or 'Universal' Water Controllers are available as an optional extra. Depending on the models chosen, these offer the following features:

- Bath fill function (Deluxe Bathroom Control Only).
- Voice Prompting (Deluxe Control Only).
- Clock (Deluxe Control Only).
- Up to four water controllers can be fitted.











For further information regarding Deluxe water controllers please contact the authorised Rinnai service company.

The "Smartstart®" system when fitted can pre-heat the water in the pipe-work between the water heater and the hot water outlets. This results in water savings and reduces waiting time for heated water at the outlets.

Operating **NOISE LEVEL IS VERY LOW**.

1.2 IMPORTANT SAFETY INFORMATION

Meaning of the symbols used in the manual for important safety information:

	Indicates a situation of potential serious danger with the risk of serious damage and/or risk of death.
	Indicates a potentially hazardous situation which, if not avoided, may in moderate or minor injury or property damage.
	Indicates a potentially hazardous situation which, if not avoided, could result in or minor injury or death or serious injury.
	Indicates a potentially hazardous situation which may cause personal problems or damage of moderate or minor entity; or suggesting the correct use of the product.
	Indicates a condition which must be complied.
	Indicates a condition which should be avoided.
	Indicates a ground connection for the prevention of an electric shock.
	Warns of a risk of fire. Keep the area clean and free from flammable materials.
	Warns of a risk of injury or property damage when contacting.
	The appliance should be installed by qualified personnel only, in outdoor, always open air and well aerated areas. Use the appliance only for water heating.

Do not modify this appliance. Do not attempt to repair, replace or open sealed parts or disassemble the appliance: improper adjustment, alteration, service or maintenance could significantly affect the safety of the product. Contact the Rinnai service if you detect any unusual condition.

Use original parts to repair the appliance.

In case of unusual noise, vibration or smell, stop the appliance and contact the Rinnai service for further information.

If you smell gas:

isolate the main gas supply;

open doors and windows;

call your gas engineer;

use a telephone outside the building.

In case of earthquake, fire, gas leak, unusual noise or smell, isolate the gas and power supply and open doors and windows.

Excessively hot water is dangerous, especially for the infirm, the elderly and young children. The appliance allows you to control the temperature of your hot water to safe levels and for all kinds of use.

Water temperature over 50°C can cause severe burns instantly or even death from scalding. Hot water at 60°C can severely burn a child in less than a second. At 50°C it takes five minutes.

Always test the temperature of the water before bathing or showering.

Do consider setting your hot water production at a maximum temperature of 50°C.

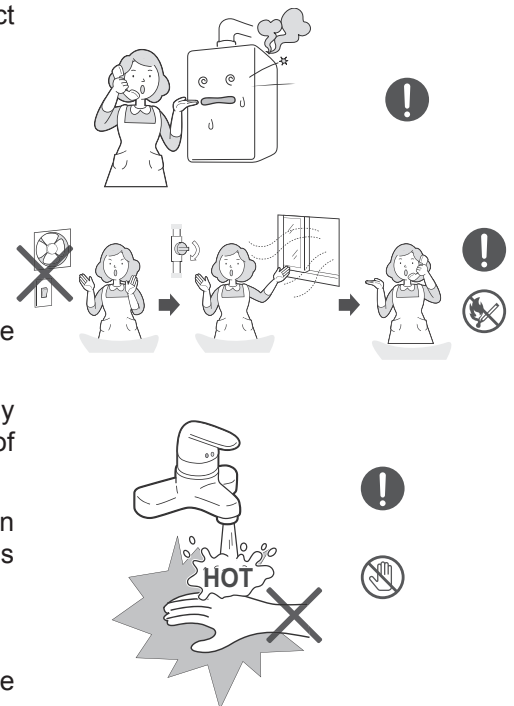

Do not store flammable objects near the appliance: it could cause a product failure or fire.

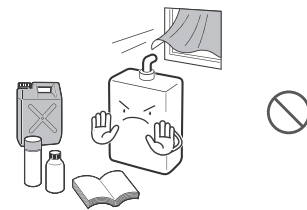

Do not spray aerosols in the vicinity of this appliance while it is in operation.

Check that the appliance is supplied with the correct gas type and pressure according to the data plate: ensure that the gas in use matches with the gas indicated on the data plate. If not, there could be incomplete burning of the gas, resulting in toxic emissions and/or product failure.

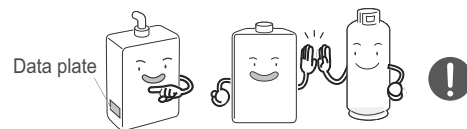

Do not insert objects into the flue outlet. Do not spray water directly into the flue outlet. Keep, trees, shrubs, etc. well clear of the flue outlet.

On colder days steam may discharged from the flue outlet. This condition is normal for high efficiency appliances and does not indicate a fault.

Check the main gas valve to make sure it is opened before using the appliance and check the gas pressure is correct.

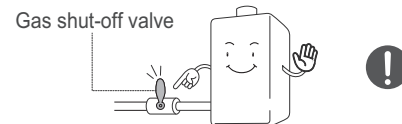

Metal flexible pipes are recommended for gas and water supply: rubber hose might get damaged.

It is recommended to install valves on the gas and water pipes to allow an easier maintenance and to increase safety in case of emergency.

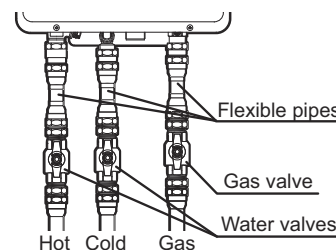

Check the voltage at the power outlet to make sure it is within the appropriate range before use.

Ensure the electrical system is provided with an appropriate grounding, otherwise the appliance could be severely damaged or operate improperly

Using a multiple socket should be avoided.

If the supply cord is damaged, it must be replaced by the manufacturer, its service agent or similarly qualified persons in order to avoid a hazard.

Prior to use after installation or if the appliance has not been used for a long time let the hot water flow for a while before using.

Do not touch the unit cover or the flue outlet.

It is recommended the installation of a system to collect and drain water under the appliance in the case of water leakage to prevent material and property damages.

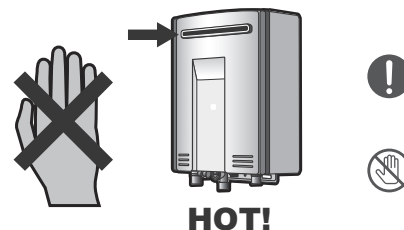
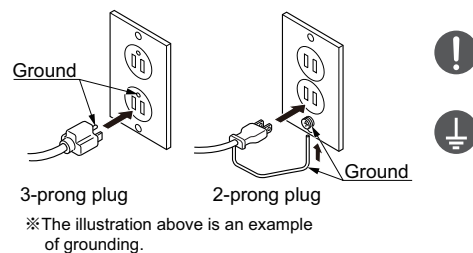

1.2.1 OPERATIONAL SAFETY INFORMATION

The following instructions and warnings describe some of the important operational features of the water heater.

IMPORTANT This appliance is not intended for use by persons (including children) with reduced physical, sensory or mental capabilities, or lack of experience and knowledge, unless they have been given supervision or instruction concerning use of the appliance by a person responsible for their safety. Children should be supervised to ensure that they do not play with the appliance.

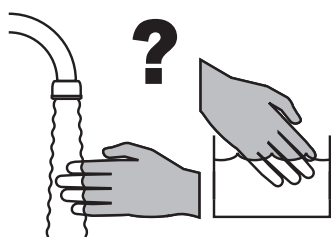

Always test the temperature of the water before bathing or showering to avoid scalding and burn.

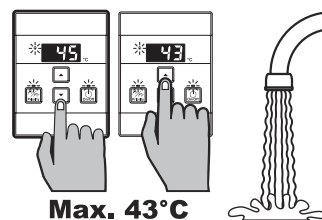

Whilst hot water outlets are open, the set temperature may be lowered. However they cannot then be raised above 43°C. In addition transfer of 'priority' between controllers is not possible. These are safety features.

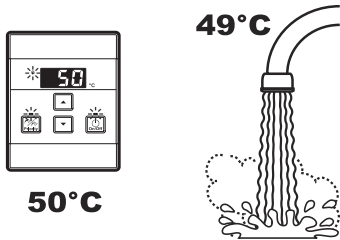

Depending on the weather conditions and the length of the pipe between the hot water unit and the outlet in use, there may be a variation between the temperatures displayed at the water controller and the temperature of the water at the outlet.

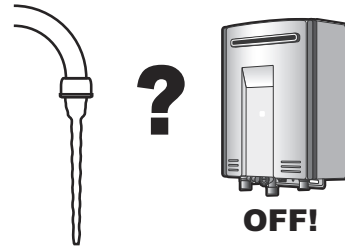

At low water flows, the hot water unit may extinguish without warning. Opening the tap further will restart the heating appliance.

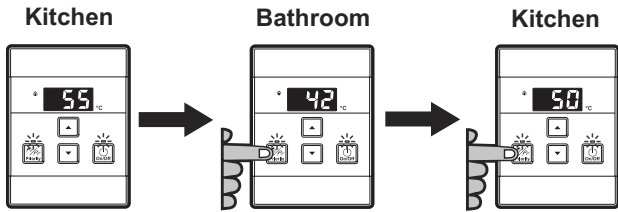

As a safety precaution, if a kitchen water controller's temperature is set above 50°C, transferring and then returning 'priority' to the kitchen water controller will result in a default set temperature of 50°C being selected. This is a safety feature.

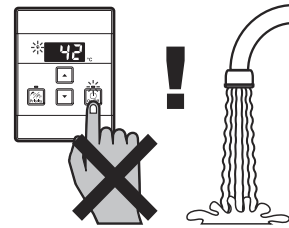

Do not push the On/Off button on any water controller when the water heater 'In Use' indicator is illuminated as this will turn off the water heater causing the water to go cold. Someone maybe in the middle of having a shower or filling a bath.

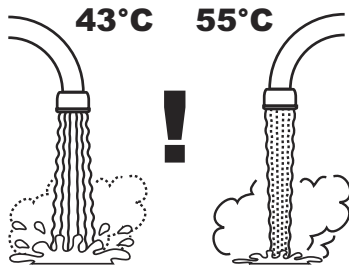

The delivered water temperature is controlled automatically. The flow may vary depending on the delivery temperature selected and the ambient water temperature.

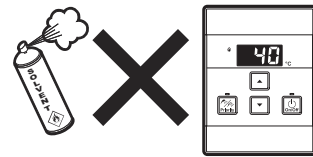

To clean your water controller use a soft damp cloth with a mild detergent. Do not use solvents!

1.3 WATER TEMPERATURE CONTROL

The purpose of a Temperature Controller is to enable the user to have localised control over the hot water supply. Used correctly, the hot water unit will supply hot water at the temperature selected, even when the water flow is varied, or when more than one tap is used.

The temperature of outgoing hot water is constantly monitored by a built-in sensor.

If the temperature of the outgoing hot water rises to more than 3°C above the selected temperature shown on the digital monitor (or the pre-set limit when water controllers are not fitted) the burner will automatically go out. The 'in use' indicator  will also go out.

The burner will ignite again once the outgoing hot water temperature falls to that shown on the digital monitor (or the pre-set limit of the appliance).

Rinnai continuous flow water heaters can be programmed to deliver higher temperatures from the master water controller, or may be programmed to restrict the maximum available delivery temperature.

Contact Rinnai for more details.

1.3.1 MAXIMUM DELIVERY TEMPERATURES

Rinnai continuous flow water heaters are factory pre-set to 60°C maximum delivery temperature.

Each temperature controller is factory pre-set to 50°C maximum delivery temperature can be individually programmed.

For the majority of applications, the factory pre-set temperature is appropriate; in the unlikely event this is not the case this setting can be increased or decreased by an authorised person such as a licensed plumber.

Adjustments to the operation of your hot water unit can be made with any of the temperature controllers.

1.3.2 OPERATION WITHOUT WATER CONTROLLERS

Rinnai continuous flow water heater products do not use a pilot light. When installed and operated, the opening of any hot water tap will automatically start the appliance. Once water is flowing through the appliance the burner will be ignited by electronic ignition. When the hot water tap is closed and water flowing through the appliance has stopped the burner flame will extinguish.

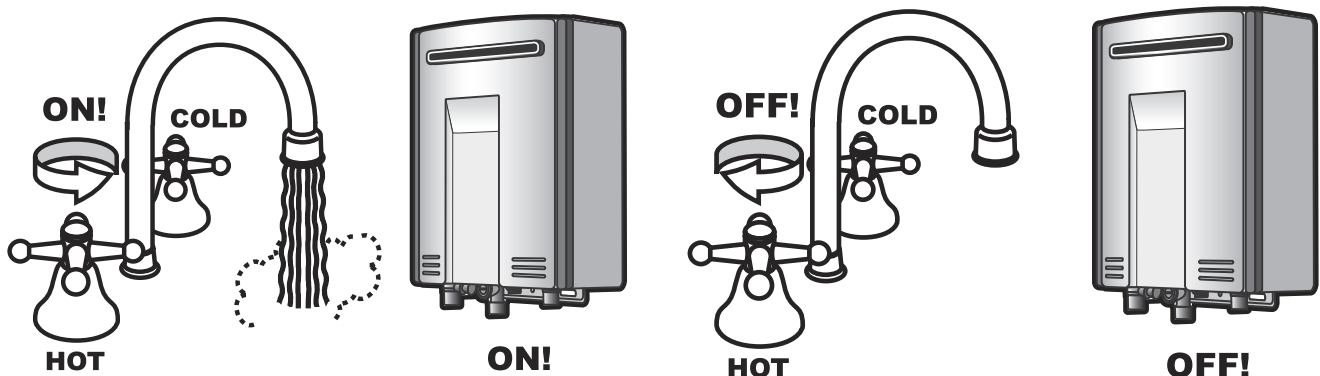

1.3.3 RINNAI WATER CONTROLLERS

Universal and Deluxe water controllers can be used together and will function as described in the dedicated section of this manual. Refer to "Water controller combinations & configurations" to confirm the maximum number and combination of water controllers that can be fitted to your water heater model. Other manufacturers water controllers are **NOT** compatible with Rinnai water heaters.

Location

Water controllers must be installed in shaded and clean locations. They should be fitted out of reach of children (suggested height from floor to be at least 1500 mm).

Water resistance

The MC-601 universal water controller is a water resistant device, however excessive exposure to water such as immersion may result in damage to the water controller. Durability of water controllers is improved when positioned outside of the shower recess.



Controllers must be installed at least 400 mm above the highest part of a sink, basin or bath.

Do not immerse the water controller into water.

Avoid direct exposure to water or steam as these conditions may cause a malfunction.

When cleaning your water controller use only a damp cloth and a mild detergent.

Temperature control

Water controllers allow precise temperature control by the user. When used correctly, the hot water unit will deliver the selected temperature, even when the water flow is varied, or more than one tap is in use.

Only one MC model water controller can be designated as a 'Master' water controller and this is normally used in the kitchen. All the remaining water controllers are designated as 'Sub' water controllers and are for use in bathrooms, toilets and laundries.

The maximum temperature limit for all 'Sub' water controllers is restricted to 50°C to minimise the risk of burns in these areas.

Each water controller can be individually programmed; however the water heater can only deliver one set temperature at any time. The available temperatures (°C) are as follows:

Water Controller Temperatures (°C)	Master (MC)	37, 38, 39, 40, 41, 42, 43, 44, 45, 46, 48, 50, 55, 60, 65 ¹
	Sub (MC or BC)	37, 38, 39, 40, 41, 42, 43, 44, 45, 46, 48, 50

¹ temperature available after PCB settings adjustment.

For hygiene in sanitary areas such as bathrooms, the suggested temperature should be 37°C ~ 43°C.

The above is a suggestion only, as you may find higher or lower temperatures more comfortable, however maintaining lower temperatures also helps to save energy.

To obtain water temperatures lower than 37°C, simply open the cold water tap and add cold water until the desired lower temperature is reached.

Universal water controllers allow temperature selection. Deluxe water controllers allow temperature selection, have a clock function and, Deluxe Bathroom water controllers, have a shower saver/bath fill function.

Contact the authorised Rinnai service company for further information regarding Deluxe water controllers.

1.3.4 WATER CONTROLLER COMBINATIONS & CONFIGURATIONS

A maximum of 4 water controllers can be fitted.

Any combination of deluxe and universal controllers can be used with the following limitations:

- Only **ONE** master controller can be installed. This can be a MC-100V, or a MC-601 (when programmed as a master controller). Note that when a MC-100V is fitted it will always function as a master controller, this is the default setting and cannot be changed.
- Up to **TWO** BC-100V water controllers can be installed.
- The **FOURTH** water controller in any installation **MUST BE** a MC-601.

When multiple temperature controllers are used they allow the temperature to be set from various locations by pushing the transfer button which gives that controller priority over the system.

The temperature selected by the controller with priority will be available to all outlets.

1.3.5 UNIVERSAL WATER CONTROLLER (MC-601) OPERATION

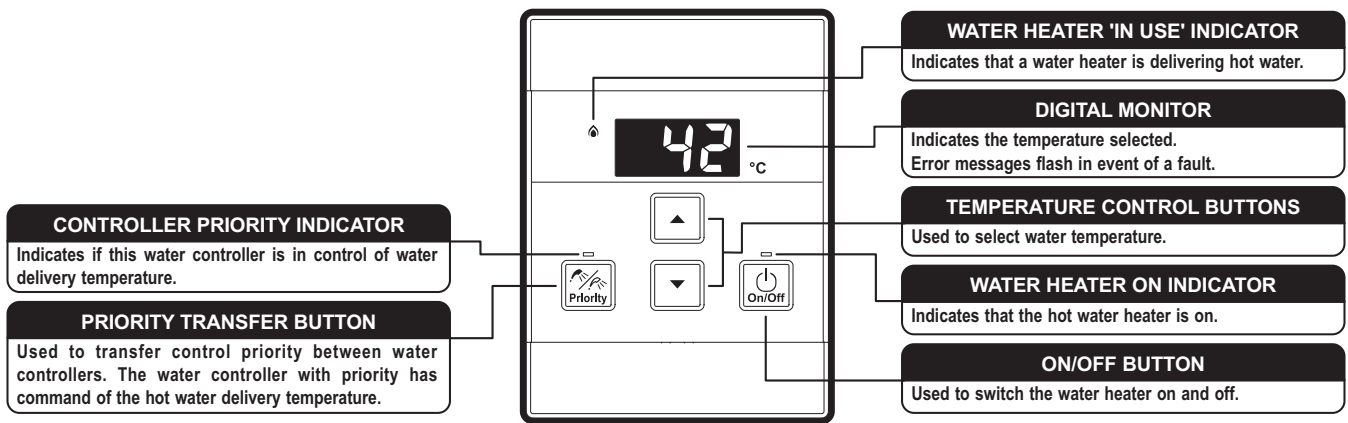

Turning on

If the water controller is switched off (no digits displayed in the digital monitor window) press the On/Off button once. The ON indicator will illuminate, indicating that the hot water unit will be ready to supply hot water once a hot water tap is opened.

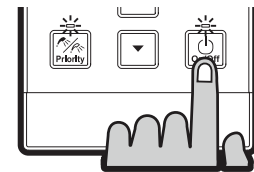

Adjusting temperature

Select the desired temperature using the Hot water temp ▲ or ▼ buttons until the required temperature is displayed on the digital monitor.

To operate the hot water unit, open any hot water tap. This will automatically light the burner providing hot water. The water heater 'In Use' indicator will illuminate on the water controller(s).

Once the hot water is running, if the set temperature is either too hot or cold press the Hot water temp ▲ or ▼ buttons until the desired temperature is reached.

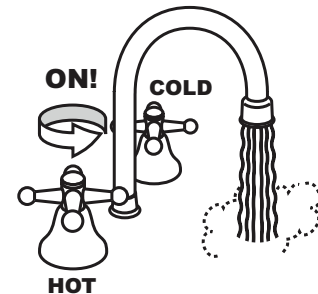

Whilst hot water outlets are open, the set temperature may be lowered to a minimum of 37°C. For safety, it cannot then be raised above 43°C until all hot water taps are closed.

Temperatures higher than 50°C must not be able to be selected on controllers installed in bathrooms, ensuites or toilets. This is to help reduce the risk of burns from hot water. If this is not the case, the controllers have been incorrectly installed. Contact your installer.

The 'beep' sound can be muted by pressing the ▲ and ▼ buttons simultaneously for more than 3 seconds. To cancel sound muting, simply repeat the process.



Always check outlet water temperature before use. The parent/carer **MUST** check the temperature before placing dependants in contact with hot water.

Transferring priority

To control the water delivery temperatures when using two or more water controllers it is necessary to have priority transferred to the water controller you wish to use. Transferring of priority will **NOT** be possible if the 'In Use' indicator is currently illuminated, as this indicates hot water is flowing and that another water controller already has priority.

An illuminated priority indicator confirms that the desired water controller is in control of the water delivery temperature. If the priority indicator is not illuminated press the priority transfer button once. The priority indicator will illuminate, indicating that hot water temperature control has been transferred and that the hot water unit will be ready to supply hot water once a hot water tap is opened.

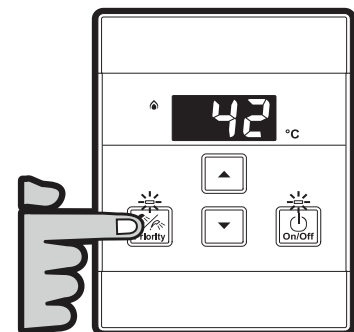

Lock function

To prevent tampering and increase the safety level of the product, especially for children, it is possible to lock the control panel.

To lock the panel it is necessary to press, and keep pressed for about five seconds, the 'Priority' keys and the key to increase the temperature (up arrow) (Fig.1). To unlock the command it is sufficient to repeat the procedure of blocking commands.

When the panel is locked, the display shows 'LOC' (Fig.2) alternating with the selected temperature on the display. All connected commands will be locked and will display the same flashing text.

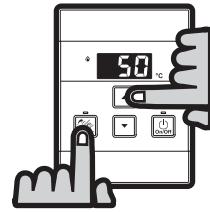

Fig. 1



Fig. 2

1.4 TROUBLE SHOOTING

Rinnai continuous flow water heaters have a self diagnostic capability. If a fault occurs, an error code will flash on the digital monitor of your water controllers. This assists with diagnosing the fault, and may enable you to overcome a problem without a service call. Please quote the code displayed when enquiring about service.

You may be able to clear the error code simply by turning the hot water tap OFF, then ON again. If this does not clear the error code, try pushing the On/Off button OFF, then ON again, or turning the power for unit OFF, waiting 10 seconds and then ON again.

If the error code still remains, contact Rinnai for advice.

1.4.1 ERROR CODES

Code	Description		Remedy
-	Noticeable reduction in water flow.		Inlet water filter needs to be cleaned - Service call.
03	Power interruption during bath fill (water will not flow on power reinstatement)		Turn off all hot water taps. Press On/Off twice.
10	Air Supply or Exhaust Blockage		Service Call
11	No Ignition (heater not turning on)		Check that the gas is turned on at the water heater, gas meter, or cylinder. If the system is LPG, make sure that gas is in the tank. Ensure appliance is properly grounded.
		licensed professional only	Ensure gas type and pressure is correct. Ensure gas line, meter, and/or regulator is sized properly. Bleed all air from gas lines. Verify dip switches and programming parameters are set properly. Ensure igniter is operational. Check igniter wiring harness for damage. Check gas solenoid valves for open or short circuits. Remove burner cover and ensure all burners are properly seated. Remove burner plate and inspect burner surface for condensation or debris. Check the ground wire for the PC board.
12	No Flame		Check that the gas is turned on at the water heater, gas meter, or cylinder. Check for obstructions in the flue outlet. If the system is LPG, make sure that gas is in the tank.
		licensed professional only	Ensure gas line, meter, and/or regulator is sized properly. Ensure gas type and pressure is correct. Bleed all air from gas lines. Ensure condensation collar was installed properly. Verify dip switches and programming parameters are set properly. Check power supply for loose connections. Check power supply for proper voltage and voltage drops. Ensure flame rod wire is connected. Check flame rod for carbon build-up. Disconnect and reconnect all wiring harnesses on unit and PC board. Check for DC shorts at components. Check gas solenoid valves for open or short circuits. Remove burner plate and inspect burner surface for condensation or debris.

Code	Description	Remedy	
14	Thermal Fuse has activated		Check for restrictions in air flow around unit and exhaust outlet.
		licensed professional only	<p>Check gas type of unit and ensure it matches gas type being used.</p> <p>Check for low water flow in a circulating system causing short-cycling.</p> <p>Ensure dip switches and programming parameters are set to the proper position.</p> <p>Check for foreign materials in combustion chamber and/or exhaust piping.</p> <p>Check heat exchanger for cracks and/or separations.</p> <p>Check heat exchanger surface for hot spots which indicate blockage due to scale build-up. Refer to instructions in manual for flushing heat exchanger. Hard water must be treated to prevent scale build up or damage to the heat exchanger.</p> <p>Measure resistance of safety circuit.</p> <p>Ensure high fire and low fire manifold pressure is correct.</p> <p>Check for improper conversion of product.</p>
16	Over Temperature Warning (safety shutdown because unit is too hot)		Check for restrictions in air flow around unit and exhaust outlet.
19	Electrical Grounding	licensed professional only	Check for low water flow in a circulating system causing short-cycling. Check for foreign materials in combustion chamber and/or exhaust piping. Check for blockage in the heat exchanger.
21	Incorrect dipswitch setting detected		Check all components for electrical short.
32	Outgoing Water Temperature Sensor		Check dipswitch settings
52	Modulating Solenoid Valve Signal		Check sensor wiring for damage. Measure resistance of sensor. Clean sensor of scale build-up. Replace sensor.
61	Combustion Fan		Check modulating gas solenoid valve wiring harness for loose or damaged terminals. Measure resistance of valve coil.
65	Water flow control fault		Ensure fan will turn freely. Check wiring harness to motor. Measure resistance of motor winding.
70	PC Board		Replace the Water flow control device.
71	Solenoid Valve Circuit		Replace the PC Board.
72	Flame Sensing Device		Replace the PC Board.

1.4.2 TROUBLESHOOTING WITHOUT WATER CONTROLLERS

If you have not installed temperature controllers and experience the following symptoms, please carry out the suggestions below. If symptoms continue, please contact Rinnai for advice.

Description	Remedy
The unit does not attempt to start at all.	Check the power is on at the unit. Check the isolation valves at the unit are open.
The unit starts then shuts down immediately.	Check the power is still on. Check the gas isolation valves at the unit and the gas meter are fully open. Open your hot water tap fully.
The unit starts then the water goes cold.	Check the power is still on. Open your hot water tap further.



Faults caused by insufficient gas supply, insufficient water supply, gas quality, water quality, installation errors or operation errors are not covered by the warranty.

1.4.3 SERVICE



A regular maintenance should be made to preserve the appliance integrity and to keep safety, efficiency and reliability unchanged.

Water controllers and water heaters do not contain user serviceable parts and must only be serviced and repaired by an authorised person.

Rinnai has a service and spare parts network with personnel who are fully trained and equipped to give the best service on your Rinnai appliance. If your appliance requires service, please call the authorised Rinnai service company.

When making a service enquiry, having both the model and serial numbers available, will help our staff quickly identify your appliance and better attend to your needs.

Always keep the appliance clean.

Unplug the appliance and turn the main gas valve off before to proceed with any cleaning or maintenance.

Clean the chassis and the remote controller using soft cloth only.

After maintenance (or cleaning), check to ensure that all the components of the appliance are intact and connected in the correct way. Exhaust gas leakage could be harmful for health or result in death.

The water heater has a filter on the cold water inlet connection. This filter will need to be cleaned occasionally. How often will be determined by the local water condition; contact Rinnai or ask your installer for information. Isolate the cold water inlet and hot water outlet with the valves near the heater. Release the pressure in the heater by unscrewing the drain valve. Then remove the filter, clean it and replace it.

If the inlet filter is clogged up, it could decrease the performance of the appliance and shorten its service life. The user should clean the filter regularly to preserve a proper operation and to prevent the appliance failure.

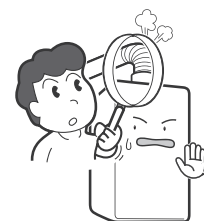
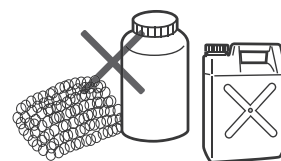

2. INSTALLER'S INSTRUCTIONS

*The following section provides specific instructions for proper installation of the product.
This section is intended for the use by qualified technical personnel.*

2.1 INSTALLATION WARNINGS



This section contains technical information concerning the installation of the product. The regulation in force and the code of practice must be followed for every aspect concerning the installation (safety and security, environment protection, etc...). According to all applicable regulations and requirements, the systems must be designed by qualified professionals only.

The Rinnai *Infinity* is conceived as continuous flow water heater. The appliance is suitable for domestic use to produce hot water. The appliance must be power plugged, gas, water and connected to a hot water delivery system suitable for the water heater power and features.

Rinnai gas appliances must be installed by qualified personnel only, according to local regulations, to the law in force and following the principles of the code of practice.

2.1.1 APPLIANCE LOCATION

This appliance is designed for '**Outdoor**' installation only. As such, it must be located in an above ground open air situation with natural ventilation, without stagnant areas, where gas leakage and products of combustion are rapidly dispersed by wind and natural convection.

This appliance must be mounted on a vertical structure with the water and gas connections on the underside pointing downwards. Location of the appliance flue terminal must be in accordance with local and national laws.

This appliance must be placed as close as practicable to the most frequently used hot water outlets to minimise the delay time for hot water delivery. For installations where the distance between the water heater and the outlets is considerable, a flow and return system or the 'circulation kit' Rinnai system can be used to minimise the waiting time for hot water delivery.

An AC 220-240V/50-60Hz, earthed power point must be provided adjacent to the appliance. For outdoor installations this power point must be weather proof. It must be clear of the gas and water connections to the appliance and also the flue exhaust and water pressure relief valve. The power cord of the appliance is 1.5 metres long.

All appliances must be installed to ensure access can be gained without hazard or undue difficulty for inspection, repair, renewal or operational purposes. Sufficient clearances shall allow access to, and removal of, all serviceable components.

This appliance must not be used as a domestic spa or swimming pool heater.

Both support brackets must be fastened with metal plugs.

The water heater must be easily accessible for maintenance.

Provide for the installation of an appropriate system to collect water from the pressure relief valve and to collect and drain water under the appliance to prevent material and property damages in case of water leakage.

The flue system must respect the minimum clearance prescriptions and applicable regulations.

Air surrounding the water heater, venting and vent termination is used for combustion and must be free of any compounds that cause corrosion of internal components. These include corrosive compounds that are found in aerosol sprays, detergents, bleaches, cleaning solvents, oil based paints/ varnishes, and refrigerants.

Do not install the appliance near combustible objects, chemical products or corrosive agents. If it is necessary for a water heater to be located in areas which may contain corrosive compounds, Rinnai strongly recommends the following: install as far away as possible from exhaust vent hoods; install as far away as possible from air inlet vents. Corrosive fumes may be released through these vents when air is not being brought in through them.

Chemicals that are corrosive in nature should not be stored or used near the water heater or vent termination.

Damage and repair due to corrosive compounds in the air is not covered by warranty.

Coastal installations

Installations located in or near coastal areas may require additional maintenance due to corrosive airborne ocean salt.

Altitude instructions

Do not install the appliance located at high altitude areas over 1,000 meters. It could cause a product failure.

2.2 UNPACKING THE WATER HEATER

Prior to use make sure that the water heater is set up for the correct type of gas and that the appliance is intact. If the appliance is clearly damaged or you have doubts do not install the water heater and contact your supplier or Rinnai immediately for further information.

2.3 DIMENSIONS

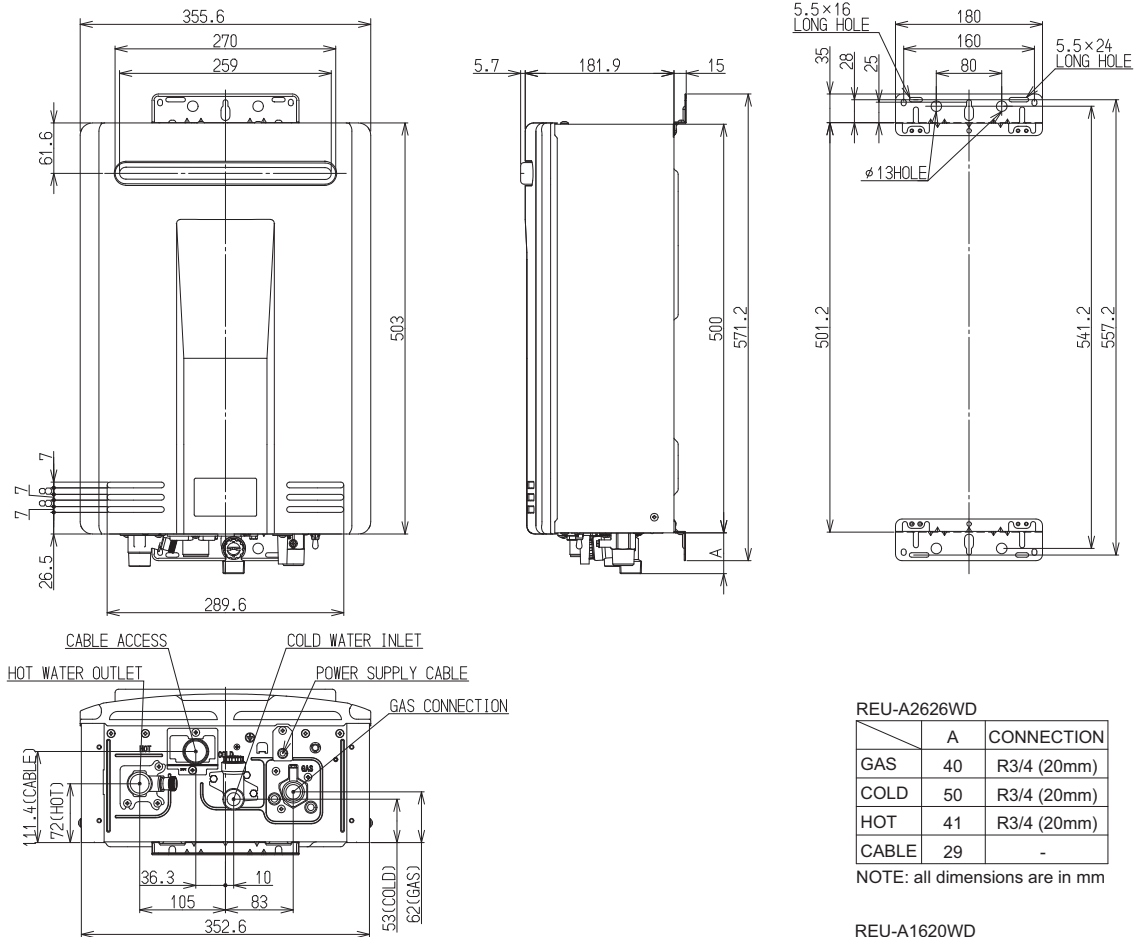

2.4 INSTALLATION

2.4.1 SELECTING A LOCATION

The appliance must be installed at the location in accordance with below diagram.

Horizontal Terminal Clearances

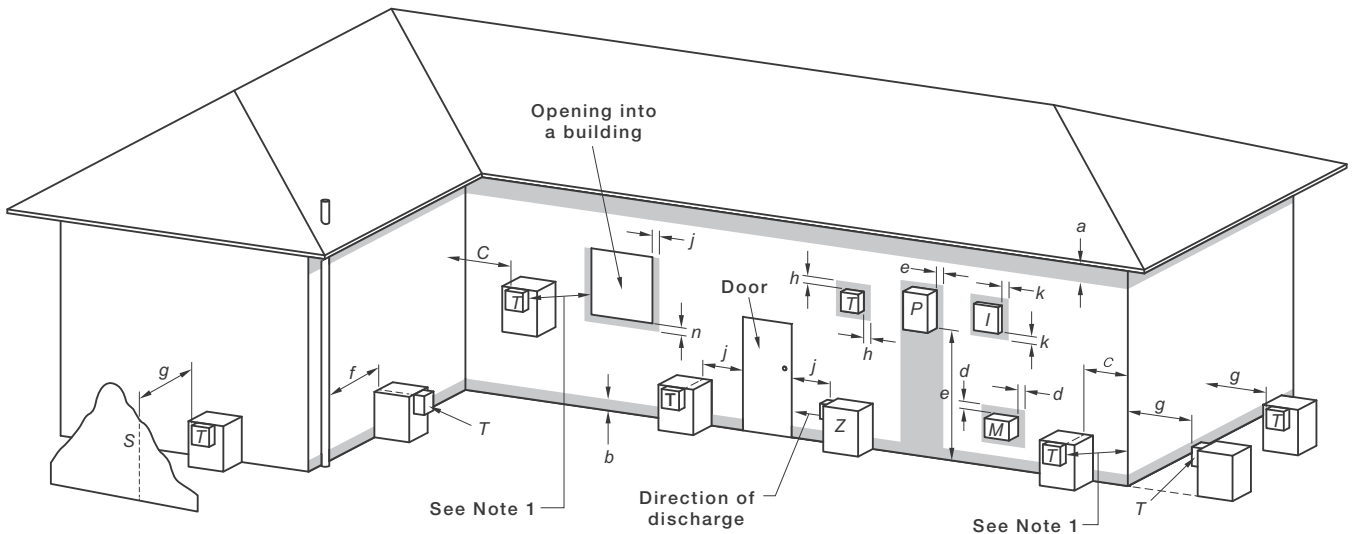

LEGEND:

- I* = Mechanical air inlet *M* = Gas meter *P* = Electricity meter or fuse box Shading indicates prohibited area for flue terminals
- S* = Structure *T* = Flue terminal *Z* = Fan-assisted appliance only

Ref.	Item	Min. Clearances (mm)
		Fan assisted
	Below eaves, balconies and other projections:	
a	For <i>appliances</i> up to 50 MJ/h input	200
	For <i>appliances</i> over 50 MJ/h input	300
b	From the ground, above a balcony or other surface *	300
c	Front a return wall or external corner *	300
d	From a <i>gas meter</i> (<i>M</i>) (see Note 5)	1000
e	From an electricity <i>meter</i> or fuse box (<i>P</i>)	500
f	From a drain pipe or soil pipe	75
g	Horizontally from any building structure* = or obstruction facing a terminal	500
h	From any other <i>flue terminal</i> , cowl, or combustion air intake *	300
	Horizontally from an openable window, door, non-mechanical air inlet, or any other opening into a building with the exception of sub-floor ventilation:	
	<i>Appliances</i> up to 150 MJ/h input *	300
	<i>Appliances</i> over 150 MJ/h input up to 200 MJ/h input *	300
	<i>Appliances</i> over 200 MJ/h input up to 250 MJ/h input *	500
	<i>Appliances</i> over 250 MJ/h input *	1500
	All fan-assisted <i>flue appliances</i> , in the direction of discharge	1500
k	From a mechanical air inlet, including a spa blower	1000
	Vertically below an openable window, non-mechanical air inlet, or any other opening into a building with the exception of sub-floor ventilation:	
	Space heaters up to 50 MJ/hr input	150
n	Other <i>appliances</i> up to 50 MJ/hr input	500
	<i>Appliances</i> over 50 MJ/h input and up to 150 MJ/h input	1000
	<i>Appliances</i> over 150 MJ/h input	1500

* Unless *appliance* is certified for closer installation.
 † Prohibited area below electricity meter or fuse box extends to ground level.

Horizontal Obstructions

The appliance must be in an accessible location. Sufficient clearances shall allow access to, and removal of, all serviceable components.

A minimum horizontal clearance of 600mm between a building structure and obstruction facing the terminal.

For correct operation of Rinnai external continuous flow water heaters such a building structure **MUST** 'obstruct' the full front cover height of the appliance (appliance dimensions, refer to "Dimensions" section), or extend vertically above and below the front cover as shown a side.

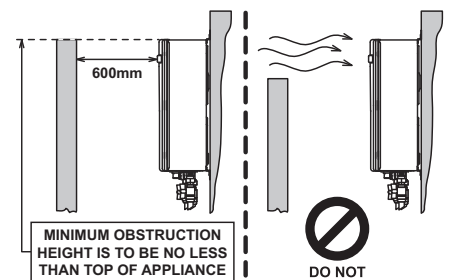

IMPORTANT There **MUST** be **NO** partial obstructions to the front cover of the appliance or any other parts of the appliance casing. This will avoid the appliance failing to operate under windy conditions.

Additional Clearance

Local codes supersede these clearances.

- Avoid termination locations near a dryer vent.
- Avoid termination locations near commercial cooking exhaust.

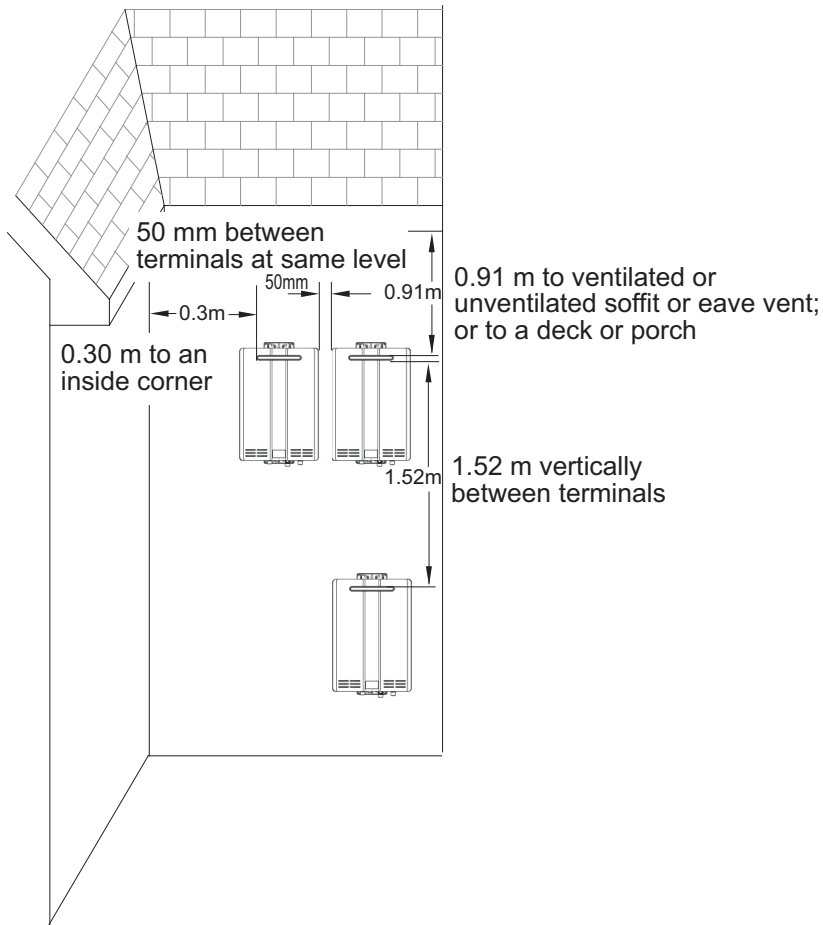

Unit clearances

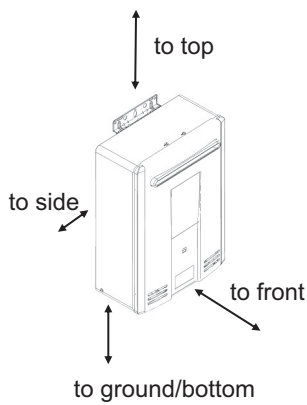

The clearance for servicing is 600mm in front of the water heater

	to Combustibles mm	to Non-Combustibles mm
Top of Heater	305	51
Back of Heater	zero	zero
Front (Panel)	600	zero
Front (Exhaust)	600	600
Sides of Heater	152	3.2
Ground/Bottom	305	51

2.4.2 WATER CONNECTION

Water pipe sizing and layout should be designed correctly to ensure the given water flows from the appliance are available.

Prior to connect the water heater and not to invalidate the warranty, water line must be cleaned to remove any impurity or production residue that could cause product malfunction.

The water connections are shown at the right table.

model	infinity 26e	infinity 16e
Water connection	20A (3/4)	15A (1/2)

Where the water supply pressure exceeds 1,000kPa(10bar), an approved pressure reducing device must be fit at the inlet of the appliance. To achieve the maximum rated flow a minimum water supply pressure of 140kPa(1.4bar) is required at the appliance inlet. The unit will operate at lower supply pressures but the maximum flow rate may not be achieved. Most installations will use high temperature setpoints which will reduce the available flow rate and heat exchanger pressure drop, and therefore less pressure will be required at the inlet. Contact Rinnai or your supplier for further instruction.

Connect the hot and cold water supply pipes. An approved isolation valve and strainer MUST be installed in the cold water inlet pipe. An approved isolation valve and draining point should be installed in the hot water outlet pipe. There must be a union or release fitting on the heater side of the isolation valves. An unvented kit to local regulations must be installed in the pipework when the system is closed (i.e. has a flow and return, or tank).

If the heater is in a hard water area a suitable water conditioning system must be installed to prevent the build up of limescale within the heat exchanger. Heat exchangers damaged by scaling are not covered by the manufacturer's warranty.

Description	pH	Total Dissolved Solids (TDS)	Total Hardness	Chlorides	Magnesium	Calcium	Sodium	Iron
Maximum Recommended Levels	6.5 - 9.0	600 mg/litre	150 mg/litre	300 mg/litre	10 mg/litre	20 mg/litre	150 mg/litre	1 mg litre

All water pipework should be insulated to optimise maximum performance and energy efficiency.

2.4.3 GAS CONNECTION

Prior to connect the water heater and not to invalidate the warranty, gas line must be cleaned to remove any impurity or production residue that could cause product malfunction.

Make sure that the appliance is set up for the correct type of gas.

The gas connection is shown at the right table.

	infinity 26e	infinity 16e
Gas connection	20A (3/4)	20A (3/4)

The size of the gas meter (or regulator) and pipework must be sufficient for all appliances on the main. The gas supply must be designed following the regulations in force and must provide the suitable dynamic pressure according to the appliance nominal power. Gas pipe sizing must consider the gas input to this appliance as well as all the other gas appliances in the premises. Sufficient gas must be available at the appliance if correct operation is to be expected; insufficient gas will damage the unit.

The available gas pressure affects directly the power output and can result in discomfort if not correct. If the gas pipe sizing is insufficient the customer will not get the full performance benefit.

An approved gas isolation valve must be fitted at the gas inlet. A union or release fitting should be installed after the isolation valve in case of emergency and for maintenance.

Fuel quality: the appliance is designed to operate with a pure gas, otherwise an appropriate filter must be installed on the gas line to restore the necessary quality

LPG tank: inert gas residues (e.g. nitrogen, etc...) could remain inside new tanks resulting in a poor gas mixture and could cause malfunction or product failure. The gases in the mixture could become stratified during storage, causing the variation of the fuel calorific value and altering the appliance efficiency.

2.4.4 ELECTRICAL CONNECTION

Connect the appliance to a 220-240V $\pm 10\%$ / 50-60Hz power supply. Do not use water or gas lines to ground the system.

The electric safety is guaranteed only when the appliance is properly grounded and the grounding system has been realized following all the safety prescriptions provided for by law.

Make sure that the electric system is suitable for the maximum power consumption and is provided with a circuit breaker with overvoltage category III.

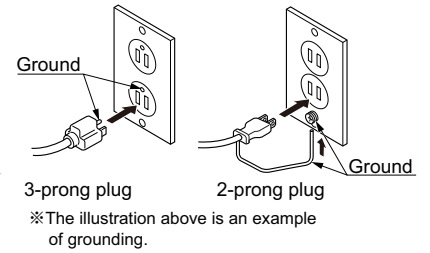

2.4.5 CONTROL BOARD DIPSWITCH SETTING

Improper setting of the switches will cause the appliance to operate incorrectly



The switches of the control board are set to without sideways flue diverter (SW1 and SW3:OFF) as default setting.

When a sideways flue diverter is fitted the installer must set switches SW1 and SW3 to ON (right position).



2.5 WATER CONTROL

2.5.1 GENERAL INFORMATION

Only one MC model water controller can be designated as the 'Master' water controller. This water controller is normally used in the kitchen and usually has a maximum temperature of 60°C, which is sufficient for almost all kitchen applications. Temperatures higher than 60°C are possible but usually unnecessary and will result in higher gas use and increase the risk of burns.

The remaining water controllers are designated 'sub' controllers and are for use in bathrooms, toilets and laundries. The temperature limit for all 'Sub' controllers is always 50°C to minimise the risk of burns in these areas.

An installation can have up to 4 universal MC-601 water controllers.

Deluxe kitchen MC-100V and deluxe bathroom BC-100V water controllers are also available and various combinations of universal and the deluxe water controllers can be used with the following limitations:

- A maximum of 4 water controllers can be fitted.
- Only **ONE** master controller can be installed. This can be a deluxe kitchen or an universal (when programmed as a master controller) water controller.



When a deluxe kitchen is fitted it will always function as a master controller, this is the default setting and can not be changed.

- Up to **TWO** deluxe bathroom water controllers can be installed.
- The **FOURTH** water controller in any installation must be an universal water controller.

For more information regarding deluxe kitchen and bathroom water controllers, contact the authorised Rinnai service company.

Location



- Do not install water controllers near a heat source, such as a cook top, stove or oven. Heat, steam, smoke and hot oil may cause damage.
- Do not install water controllers outdoors unless protection from water/dust ingress and sunlight are provided.
- The water controller set as the master water controller must not be installed in a bathroom.
- Do not install water controllers in direct sunlight.
- Do not install water controllers against a metal wall unless the wall is earthed.
- Water controllers must not be installed where chemicals such as benzene, alcohol, turpentine, hydrogen sulphide, ammonia, chlorine or other similar chemicals are in use.

The Water controller is a water resistant device, however excessive exposure to water may result in damage to the water controller. Durability is improved when positioned outside the shower recess.

- Avoid direct exposure to water or steam as these conditions may cause a malfunction.
- Water controllers must be installed in shaded and clean locations. They should be fitted out of reach of children (suggested height from floor to be at least 1.5m). Water controllers must be installed at least 40cm above the highest part of a sink, basin or bath.
- When cleaning your water controller use only a damp cloth and a mild detergent.

Communication cables

The communication cable for the optional temperature controller (12 Volts DC) should be a non-polarized two-core cable with a minimum gauge of 0.64 mm(22AWG). The maximum cable length from each controller to the water heater depends on the total number of wired controllers connected to the water heater.

Number of Wired Controllers	Maximum Cable Length for each Controller to Water Heater
1	100 m
2	50 m
3 or 4	20 m

It is not recommended to install the communication cable near by house electric cables: interference may easily happen causing system malfunctions. In these cases we recommend to use proper shielded cables.

When connecting the cables to water controller or heater the polarity is not important: either colour wire can be connected to either terminal.

The water heater end of the cables are fitted with spade terminals. Only two pairs of cables (4 spade connectors in total) may be terminated. When attaching three or four cables it is necessary to join the cable terminals as follows:

For each pair cut off the existing spade connectors and re-terminate each pair into a new spade connector (A) (spade connectors are available from your local electrical component retailer) so that there are only two sets of spade connectors (4 spade connectors in total) to be terminated.

Single cables can be used when terminating up to two communication cables.

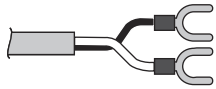

Paired cables are to be used when terminating three or four communication cables.

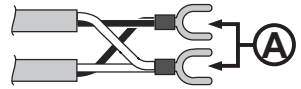

Connecting One or Two Communication Cables

Follow steps 1 through 5 of "Communication Cable(s) & 'Ezi connect'" to terminate the cables to the water heater.

Connecting Three or Four Communication Cables

To connect three or four cables, separate all the cables to be fitted into pairs.

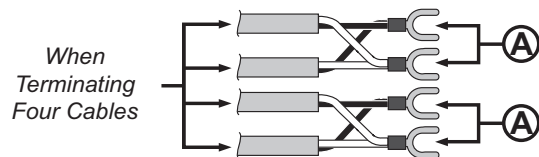
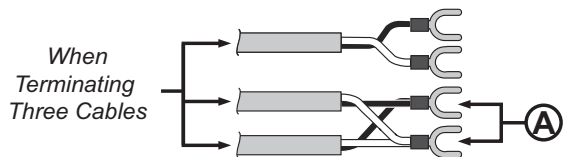

Follow steps 1 through 5 of "Communication Cable(s) & 'Ezi connect'" to terminate the joined cable pairs to the water heater.

Communication Cable(S) & 'Ezi connect'



Do not attempt to connect cables to the 'Ezi connect' cable connector at the water heater unless the electric power to the water heater is switched 'off' otherwise damage to electrical components may occur.

1. Isolate the electric power supply by switching the power point off and removing the power plug of the water heater from the electric power socket.
2. Remove the retaining screw (A) of the 'Ezi connect' cable connector at the base of the appliance.
3. Swing the 'Ezi connect' cable connector door open and thread the cable through the weather seal of the cable access hole (B) in the direction shown allowing sufficient cable length so that the sheath of the cable can be secured with cable clamp (C) .
4. Loosen screw terminals (D) & (E) and connect the cable spade connectors to these terminals and re-tighten.

Polarity is not important, either wire colour can be connected to either terminal.

5. Return the 'Ezi connect' cable connector to the original position taking care not to damage cable wires in the process and replace the retaining screw (A).

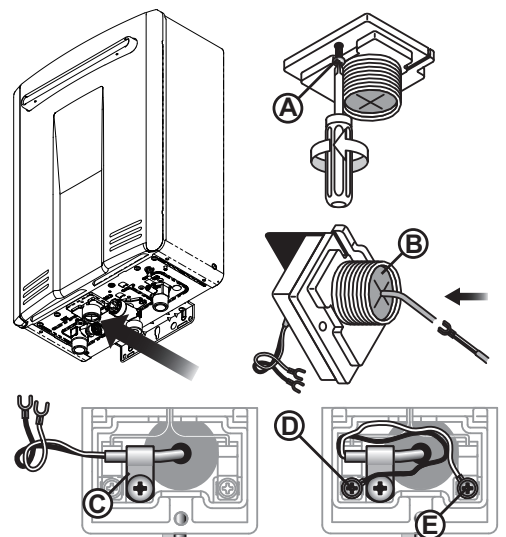

2.5.2 UNIVERSAL WATER CONTROLLER (MC-601) INSTALLATION

1. Determine the most suitable position.
2. Mark and drill 3 holes (mounting and cable access) for water controller dimensions.

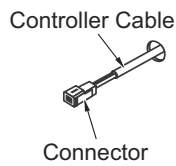
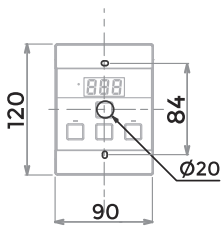

Fig. 1

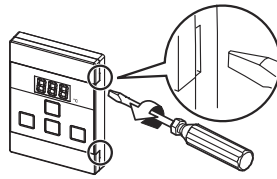

Fig. 2

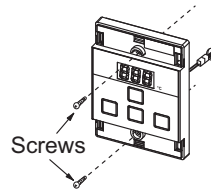

Fig. 3

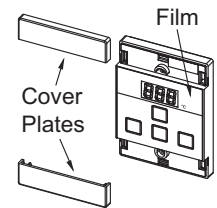

Fig. 4

3. When running cable through the access hole ensure the connector end of the cable is located nearest to the water controller (Fig. 1).
4. Carefully pry the cover plates from the water controller, using a screw driver (Fig. 2).
5. Connect the cable to the water controller. Feed any excess cable lengths into the wall cavity to avoid the pinching of cables between the wall and the water controller.
6. Fix the water controller to the wall using the appropriate fixings (Fig. 3).
7. Remove protective film from the water controller face and replace the cover plates (Fig. 4).

Additional programming and activation requirements



1

Are there four water controllers connected?

IF NO: You have three (or fewer) water controllers, go to Question 2.

IF YES: You will need to activate the fourth water controller as follows:

STEP 1: For the water controller in the kitchen only, press and hold the 'Priority transfer' and 'On/Off' buttons simultaneously (see Fig. 1) until a 'beep' is heard (approximately 5 seconds).

STEP 2: Check that the display on all four water controllers is lit and displaying a temperature when 'switched on'. If any one of the water controller displays two dashes (see Fig. 2) repeat STEP 1.

This completes the activation procedure for the fourth water controller, you may ignore Question 2.

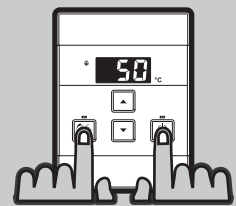

Fig. 1



Fig. 2



2

Is the water heater marked to state it delivers water not exceeding 50°C?

IF YES: No further action required..

IF NO: You will need to program the kitchen water controller to enable selection of temperatures higher than 50°C.

STEP 1: For the water controller in the kitchen only, press and hold the 'Priority transfer' and 'On/Off' buttons simultaneously (Fig. 3) until a 'beep' is heard (approximately 5 seconds).

STEP 2: When the water controller fitted in the kitchen is switched On, it should be possible to select temperatures higher than 50°C. If not, repeat STEP 1.

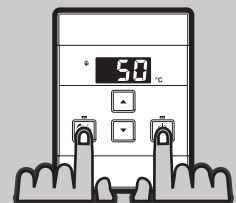

Fig. 3



If the water controller in the kitchen is replaced, repeat STEP 1 for the replacement water controller.

If the water controller in the kitchen is swapped with another water controller (for example, the water controller fitted in a bathroom), repeat STEP 1 for the water controller moved from the kitchen to the bathroom. Then perform STEP 1 for the water controller moved from bathroom to the kitchen.

2.6 COMMISSIONING

- Make sure the water heater is not subject to corrosive compounds in the air.
- Check the water supply does not contain chemicals or exceeds total hardness that will damage the heat exchanger.
- Verify the clearances from the water heater and from vent termination/air intake unit are met.
- Ensure that a manual gas control valve has been placed in the gas (& water) line to the water heater.
- Before final connection of the water heater purge gas, hot water and cold water supply lines. Debris or swarf in either the gas or water supplies may cause damage.
- Clean the inlet water filter by closing the cold and hot water inlet isolation (shut-off) valves. Put a bucket under the filter at the bottom of the water heater to catch any water that is contained inside the unit. Unscrew the water filter.
Rinse the filter to remove any debris. Install the filter and open the isolation valves.
- Turn on gas and cold water supplies and test for water leaks and gas escapes near the unit.
- Ensure that hot and cold water lines are not crossed to the unit and are leak free.



Remove front panel and confirm the control board dipswitch settings are set to the correct positions as required: factory default or sideways flue diverter fitted.

Fix the front panel back.

- Isolate gas supply. Remove test point screw located on the gas inlet connection and attach pressure gauge.
- Turn the power 'on' at the power point socket and turn on gas.
- If water controllers are fitted, ensure they are 'ON', with the maximum delivery temperature selected and open all available hot water outlets.
- If water controllers are not fitted, simply open all available hot water outlets.



Ensure building occupants do not have access to hot water outlets during this procedure.

- Operate all other gas appliances at their maximum gas rate, in accordance with manufacturers instructions.
- With all gas appliances in operation at maximum gas rate, the pressure should read between 2.5kPa on natural gas. On LPG the pressure should be 2.8kPa. If the pressure is lower, the gas supply is inadequate and the appliance will not operate to specification. It is the Installers responsibility to check the gas meter, service regulator and pipe work for correct operation/sizing and rectify as required.



The gas regulator on the appliance is electronically controlled and factory pre-set. Under normal circumstances it does not need adjustment during installation.

- Close hot water taps including the shower.
- Inspect and clean the strainer located on the cold water inlet connection. This procedure may need to be repeated to ensure the strainer remains clear, especially on new installations.
- If water controllers are fitted, it is necessary to test their operation through the complete range of functions.
- Confirm the hot water delivery temperature using a thermometer. If controllers are fitted, ensure temperatures exceeding 50°C cannot be selected on bathroom or toilet.
- After testing is completed, explain to the householder the functions and operation of the water heater and water controllers (if fitted).
- Inform customer on use of an adequate water softening system to prevent damages to heat exchanger.
- Leave the manual to customer.
- If the water heater is not needed for immediate use, then drain the water from the heat exchanger.

2.7 TECHNICAL DATA

Infinity Model	REU-A1620WD-GEN	REU-A2626WD-GEN	Unit
Installation	External, outdoor		
Flue system	Direct forced exhaust		-
Temperature range with water controller	37-46, 48, 50, 55, 60, 65		°C
Temperature range with push buttons	40, 42, 50, 55, 60, 65		°C
Ignition	Direct electronic ignition		-
<u>Gas consumption</u>			-
Natural Gas: Input	34.4	55.3	kW
LPG Input	34.4 (2.5kg/h)	55.3 (3.9kg/h)	kW
Output	27.9	44.8	kW
Gas type and pressure	Natural gas – 2.5 kPa, LP gas – 2.8 kPa		-
Type	Outdoor installation		-
Max water flowrate	20	26	L/min
Min operation flowrate	ON=1.5 / OFF=1.0 ¹		L/min
Min operating water pressure (Pmin)	10		kPa
Water pressure (@nom/max flowrate-max) - (Pw)	100/150-1000		kPa
Power supply	220-240V / 50-60Hz		-
Electric consumption (remote/standby+remote)	43/2	62/2	W
Noise level	54	56	dB (A)
Weight	13.5	15.5	kg
IP protection	IPx5D		-

¹ minimum water flowrate may vary depending on the temperature setting and the inlet water temperature.

Memo

Memo

Memo

Quality system standard

ISO 9001

The design, development and manufacture of gas water heating appliances done under Rinnai's quality management system is certified under the quality management system Standard ISO 9001.

Certified by: *Japan Gas Appliances Inspection Association - JIA-QA Center*

Rinnai

Web. <http://www.rinnai.com>



060 00012 30107 6

U340-1752(01) 