

MODELS:
REI-A380AP
REI-A380DP
REI-A380DP-R (rainshower)

MODELS:
REI-A330NP
REI-A330NP-R (rainshower)
REI-A330DP
REI-A330DP-R (rainshower)

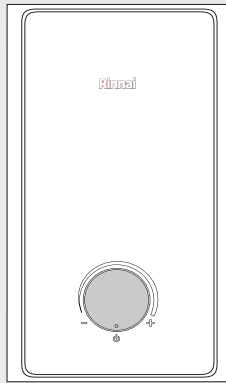

Electric Instant Water Heater

Instructions for use, installation, and connection

Rinnai

	Pages
Introduction	3
Important Safety Information	4
Part Contents Checklist	5 - 6
Parts Description	7 - 9
Rain Shower Accessory Installation Guide	10
Electrical Requirements	11
Water Requirements	12
Installation	13 - 14
Fitting The Shower Set	15
Commissioning	16 - 17
Operating The Shower	18
User Maintenance	19
Troubleshooting	20
Specification	21 - 23

Congratulations!

Thank you for making excellent choice by purchasing the **Rinnai Instantaneous Water Heater**.

Please read these instructions carefully for optimum performance, necessary fitting and operating instructions.

Your **Rinnai Instantaneous Water Heater** has been manufactured in a ISO9001 registered company which provides you with assurances of its quality safety and environmental friendly.

Caution!

Read all of these instructions and retain this guide for later use.

Pass on this guide in the event of change of ownership of the installation site.

Follow all warnings, cautions and instruction contained in this guide, and on or inside appliance.

Anyone who may have difficulty understanding or operating the controls of any shower should be attended whilst showering. Particular consideration should be given to the young, the elderly, the infirm, or anyone inexperienced in the correct operation of the controls as well as children should be supervised to ensure that they do not play with the appliance.

When this appliance has reached the end of its serviceable life, it should be disposed of in a safe manner, in accordance with current local authority recycling or waste disposal policy.

1. Warning!

1.1. Products manufactured by us are safe and without risk provided they are installed, used and maintained in good working order in accordance with our instructions and recommendations.

1.2. THIS APPLIANCE MUST BE EARTHED, TO MAKE SURE EARTH WIRE AND HEATER UNIT HAVE PROPER GROUNDING IN HOUSEHOLD.

Earthing Requirement:

The Earthing installation should be carried out in accordance with the local Wiring Regulations. **Where EARTHING of the premises is not evident, it is necessary to run an EARTH CONDUCTOR and solidly connect an earth rod local to the installation.** The following notes are for guidance only:

- 1.2.1 Select a damp place to bury the earth rod.
- 1.2.2 Connect earth conductor of minimum 2.5mm² (7/0.67mm) to the appliances Earth (⊕) terminal. Connect other end of the earth conductor to the earth rod.
- 1.2.3 Check to ensure earthing resistance is less than 100Ω. It may be necessary to drive two or more rods and connect them together to achieve a satisfactory results.
- 1.2.4 Installation of earth rod must be carried out by a registered and certified wiring contractor.

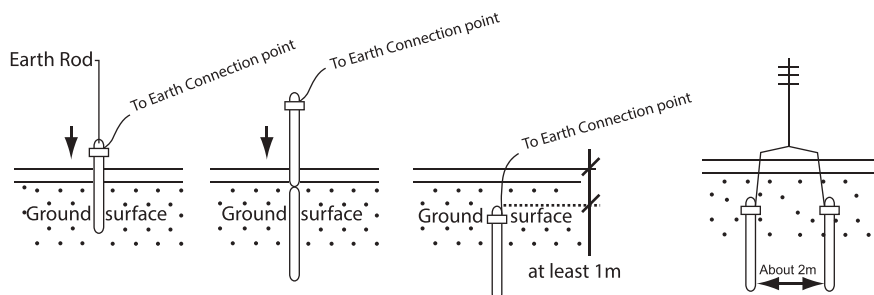

- 1.3. **DO NOT** allow the unit to be run dry.
- 1.4. **DO NOT** fit any form of outlet flow control as the outlet acts as a vent for the tank body. Once recommended outlet fittings should be used.
- 1.5. There are no user serviceable components beneath the cover of this appliance. Only a competent tradesperson should remove the cover.
- 1.6. If the cover is not correctly fitted and water has entered the case. Isolate the electrical and water supply before removing the cover.
- 1.7. Mains connections are exposed when the cover is removed.
- 1.8. Refer to the wiring diagram before making any electrical connections.
- 1.9. Ensure all electrical connections are tight, to prevent overheating.

Part Contents Checklist (For Unit C/W Normal Shower Accessories) 5

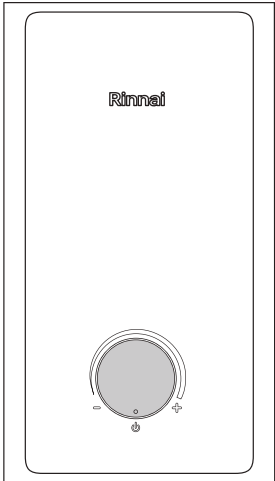

Rinnai

1 x Rinnai Heater Unit

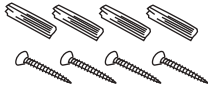

4 x Green Wall Plug & Screw Set



1 x Sliding Rail



1 x Shower Holder

Rail Support c/w
4 x White Wall Plug & Screw Set

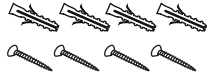
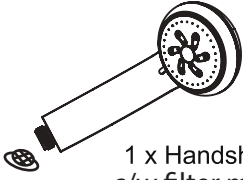
1 x Handshower
c/w filter mesh washer

1 x Flexible Hose
c/w 2 pcs washer

1 x Stop Valve
c/w 1 pc washer

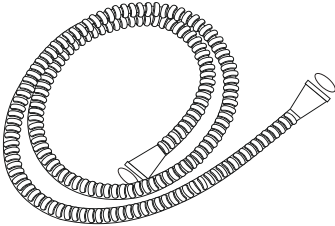
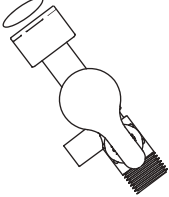
Part Contents Checklist (For Unit C/W Rain Shower Accessories)

6

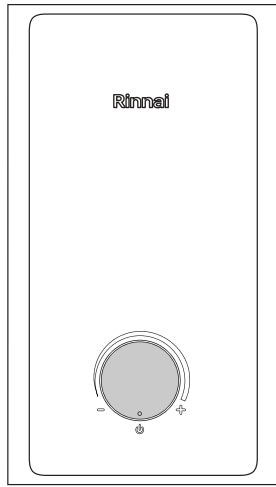

1 x Rinnai Heater Unit

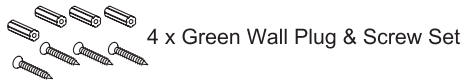

4 x Green Wall Plug & Screw Set

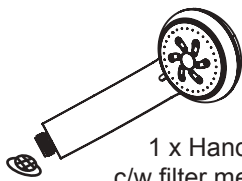

1 x Handshower
c/w filter mesh washer

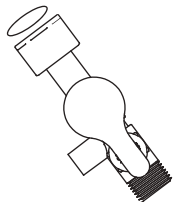

1 x Stop Valve
c/w 1 pc washer

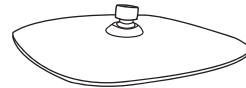

1 x RS Shower Head

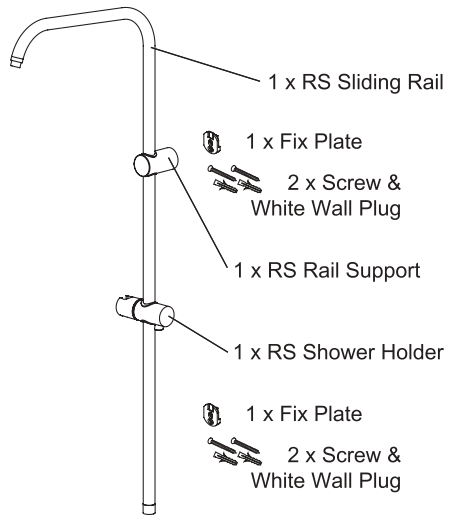

1 x RS Sliding Rail

1 x Fix Plate

2 x Screw &
White Wall Plug

1 x RS Rail Support

1 x RS Shower Holder

1 x Fix Plate

2 x Screw &
White Wall Plug

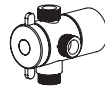

1 x 3 Way Diverter Valve



1 x Fix Plate



2 x Screw & White Wall Plug

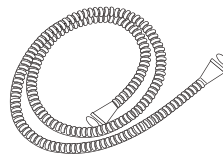

1 x 5' Flexible Hose
c/w 2 pcs washer

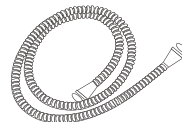

1 x 3' Flexible Hose
c/w 2 pcs washer

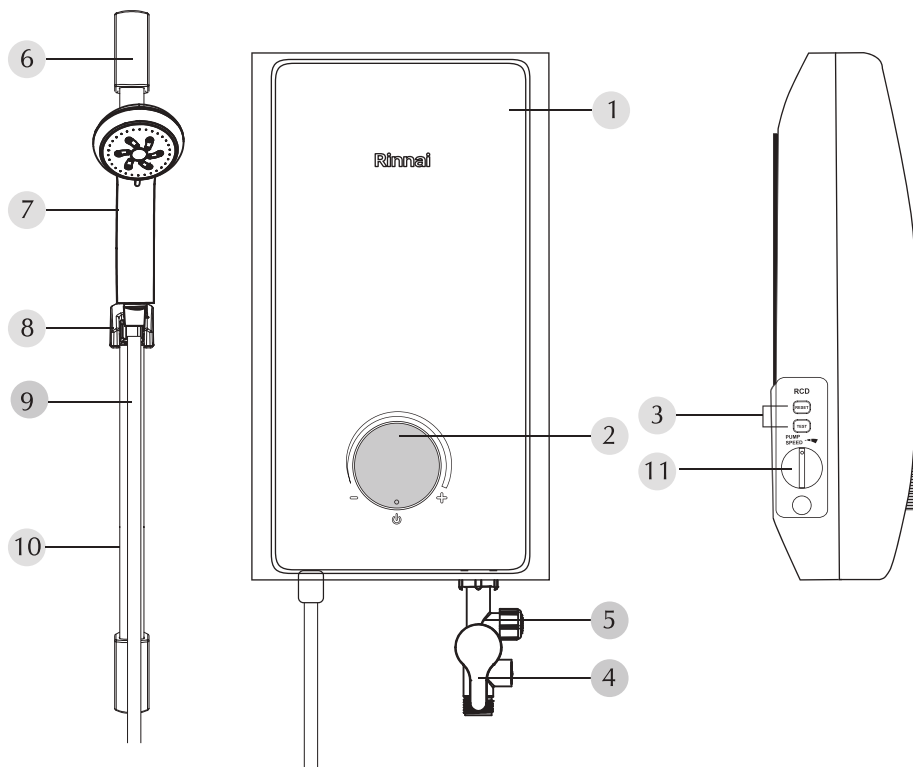

- 1. Heater Cover
- 2. Power Control Knob
- 3. RCD Test Reset button (for RCD model only)
- 4. Stop Valve
- 5. Regulator Valve
- 6. Rail Support (2 Nos)
- 7. Handshower
- 8. Shower Holder
- 9. Flexible Hose
- 10. Sliding Rail
- 11. Pump Speed Control (for REI-AP / DP Series only)

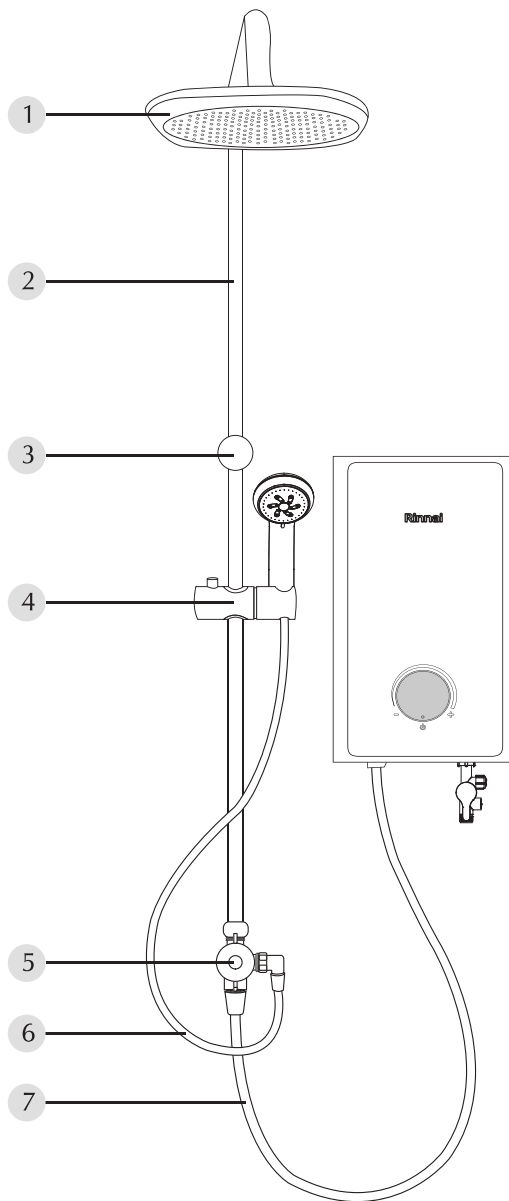

- 1. RS Shower Head
- 2. RS Sliding Rail
- 3. RS Rail Support
- 4. RS Shower Holder
- 5. 3 Way Diverter Valve
- 6. 5' Flexible Hose
- 7. 3' Flexible Hose

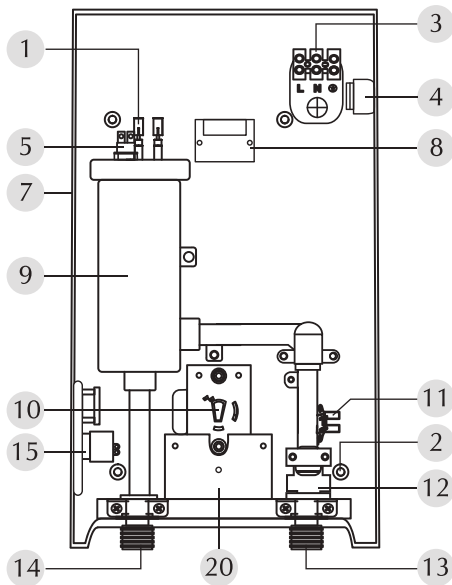

MODELS: REI-A330NP / REI-A330NP-R

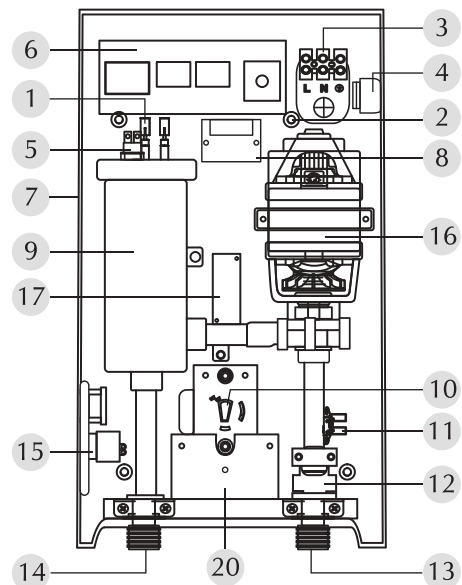

MODELS: REI-A380AP

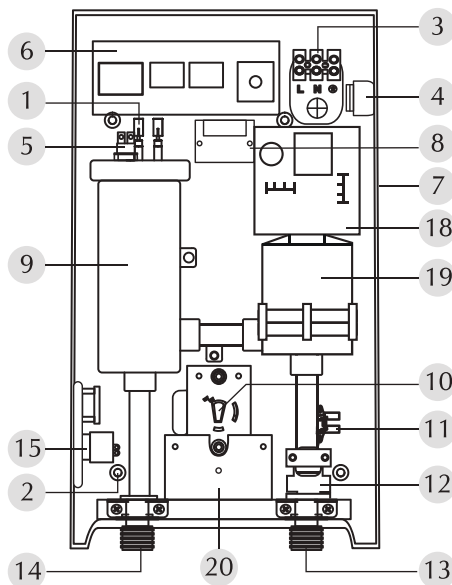

MODELS: REI-A380DP / REI-A380DP-R
: REI-A330DP / REI-A330DP-R

1. Heating Element
2. Mounting Holes (4 Nos)
3. Terminal Block
4. Cable Entry
5. Thermostat
6. RCD Assembly (for RCD model only)
7. Heater Base
8. Back Light PCBa
9. Water Tank
10. Electronic Control
11. Triac
12. Flow Switch Assembly
13. Water Inlet
14. Water Outlet
15. Pump Speed Control
16. Pump Assembly (AC)
17. PC - 2D Board (AC)
18. LVDC Board (DC)
19. Pump Assembly (DC)
20. Power LED PCBa

1. Drill holes and insert wall plugs provided according to the recommended dimension as shown (2 holes).
Note: Height of the installation is at the discretion of the user.
2. Secure the Fix Plate (2 units) with screws provided.
3. Secure the Rainshower(RS) Shower Head to Rainshower(RS) Sliding Rail as shown.
4. Secure Rainshower(RS) 3 Way Diverter to Rainshower(RS) Sliding Rail.
Note: Be sure to insert a rubber washer provided.
5. Fix the assembly into Fix Plates by inserting Rainshower(RS) 3 Way Diverter and Rainshower(RS) Rail Support into Fix Plate.
6. Connect 3' Flexible Hose from heater outlet to bottom of Rainshower(RS) 3 Way Diverter.
Note: Be sure to insert a rubber washer provided.
7. Connect 5' Flexible Hose to Handshower and another end to Rainshower(RS) 3 Way Diverter outlet (RIGHT).
Note: Be sure to insert a washer before Handshower & rubber washer provided between hose and outlet of Rainshower(RS) 3 Way Diverter.
8. Rainshower assembly are ready for use.
9. SHOWER OPTIONS :

-  HANDSHOWER & RAINSHOWER
-  HANDSHOWER ONLY
-  RAINSHOWER ONLY

***Due to limitation on product's heating element power and rainy season (decrease in ambient temperature), the instant water heater with Rain Shower maybe running with higher water volume compared to Hand Shower, hence not be able to produce hot water to desired temperature. Users are advised to either, decrease the flow rate at stop valve or lower down the Pump Speed Control (for pump model).**

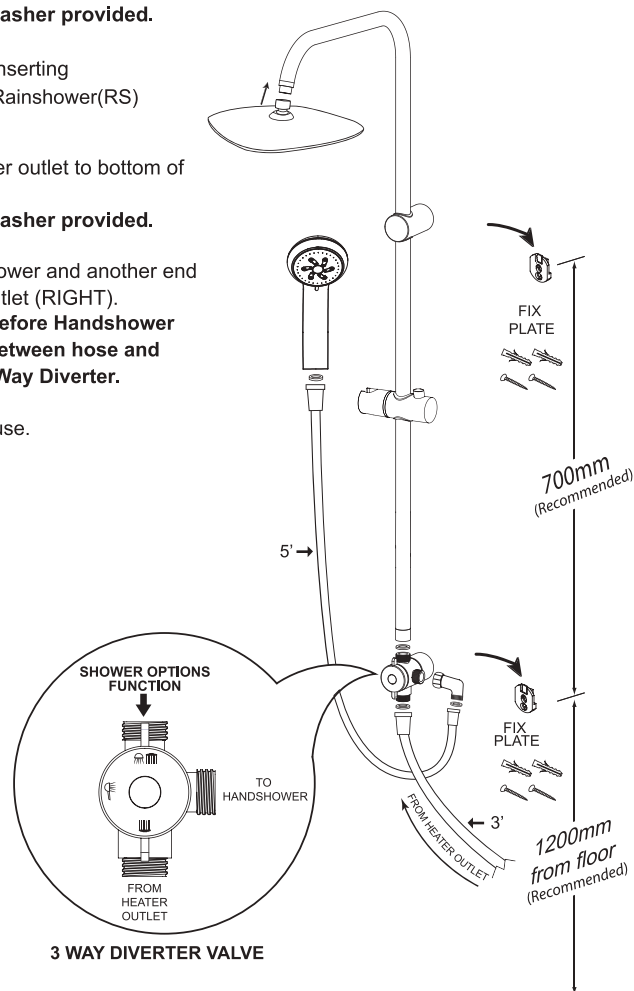

WARNING 
THIS APPLIANCE MUST BE EARTHED

- 1) Installation must be carried out by a qualified electrician.
- 2) The shower heater unit must be connected to its own independent electrical circuit.
- 3) Lead the power cable from the indoor fuse distributor board or Miniature Circuit Breaker (MCB) to a **10mA RCD** and from RCD to 'ON/OFF' Double-Pole switch outside the bathroom.
Please refer to Bathroom General Wiring layout below.
- 4) The water heater must be permanently connected to the electricity supply through a double-pole linked switch having a contact of separation of at least 3mm in all poles incorporated in fixed wiring.
- 5) This switch must be out of reach of a person using a shower.
- 6) The use of a plug and socket is not recommended.
- 7) Correct size of wire conductor corresponding to different electrical loading should be used.
(Refer cable size table below)

Cable Sizes Table

Country	Voltage (V~)	Power (kW)	Amperes (A)	Cable Size (mm ²)	Fuse / MCB (A)	ON / OFF Switch (A)
Malaysia	240V ~ 50Hz	3.8	15.9	4.0	20	20
Singapore	230V ~ 50Hz	3.3	14.4	4.0	16	20
Cambodia & Myanmar	220V ~ 50Hz	3.5	15.9	4.0	20	20
Philippines & Vietnam		4.5	20.5	4.0	30 / 32	30 / 32
Thailand		5.5	25.0	4.0	30 / 32	30 / 32

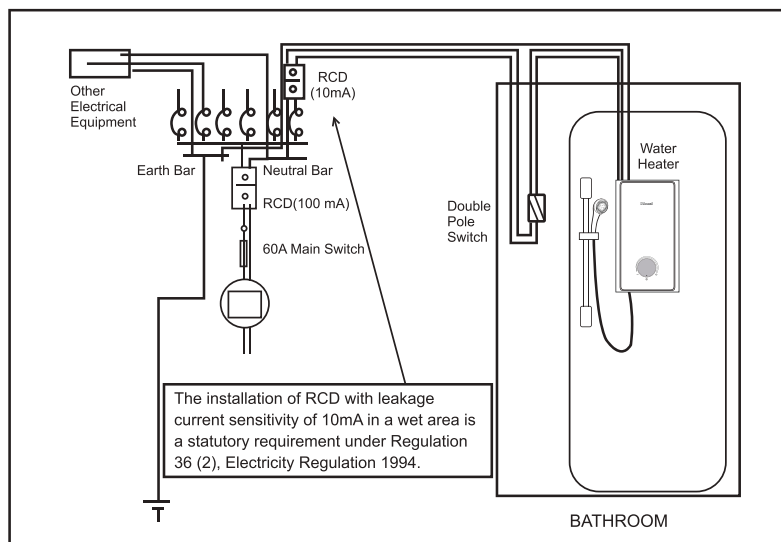

Plumbing Schematic Diagram

An electric water heater can be fitted in your home regardless of the type of plumbing system as in most cases they can operate directly off the main cold water supply.

Fig. shows a typical system layout. Do not use jointing compounds on any pipe fittings for the installation.

The Unit works at minimum water flow rate of 2 litre/min.

SITING OF THE SHOWER

WARNING: The shower must not be positioned where it will be subjected to freezing conditions.

FOR EASE OF SERVICING, THE UNIT MUST ALWAYS BE MOUNTED ON THE SURFACE OF TILED WALLS. NEVER TILE UP TO THE UNIT.

This product is splash-proof rated and is approved for use in shower cubicles and over baths.

However, do not install the unit in a position where the sprayhead will consistently direct water over it.

The shower unit MUST be positioned vertically.

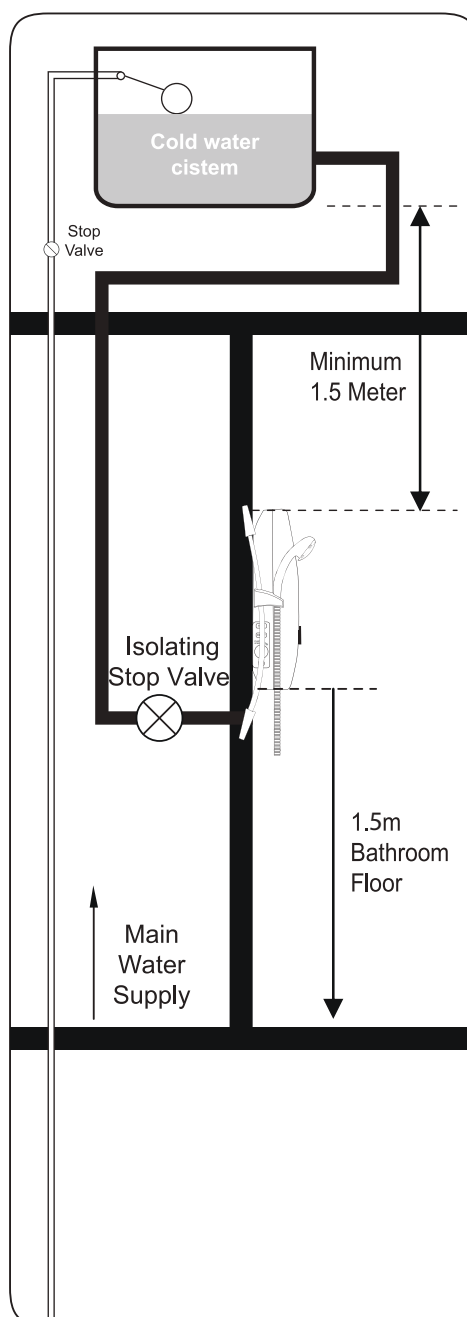

FIXING THE SHOWER TO THE WALL

Important: The shower must be mounted on a flat surface which covers the full width and length of the backplate. It is important that the wall surface is flat otherwise difficulty may be encountered when fitting the cover and subsequent.

1.1 Decide on a suitable position to allow for cover fit and removal.

Determine the direction that you require the inlet water supply and electrical cable to enter the unit from.

Determine the height at which you require the unit to be installed.

1.2 Unscrew the cover retaining screws sufficient to remove the cover.

Note! The cover retaining screws are captive and should remain in the case.

1.3 Remove the cover.

Mark the position of the unit on the wall. Mark the positions of the fixing holes. Make sure that sufficient electrical supply cable is available for connection to the terminal block.

1.4 Drill the holes and insert the wall plugs provided. Secure the heater unit to the wall with the screws provided. Avoid drilling into any supply cable/pipe.

Note! Hook the backplate over the top screws and fit the lower fixing screw into position. **DO NOT** fully tighten the screws at this stage, as the fixing holes are elongated to allow for out of square adjustment after the plumbing connections have been completed.

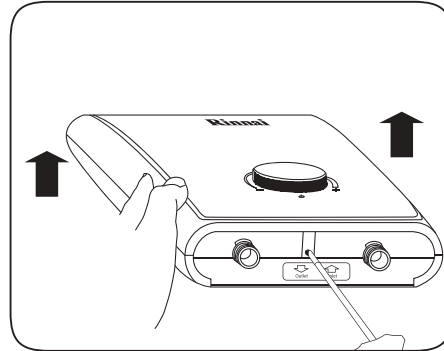

Remove the Cover

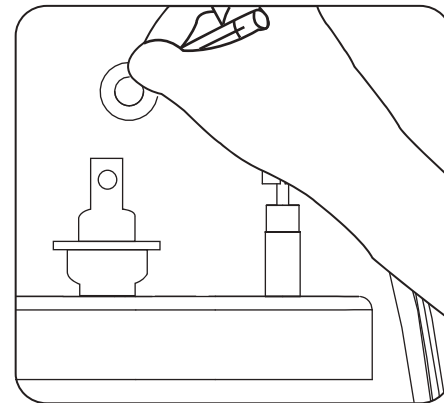

Mark the mounting holes

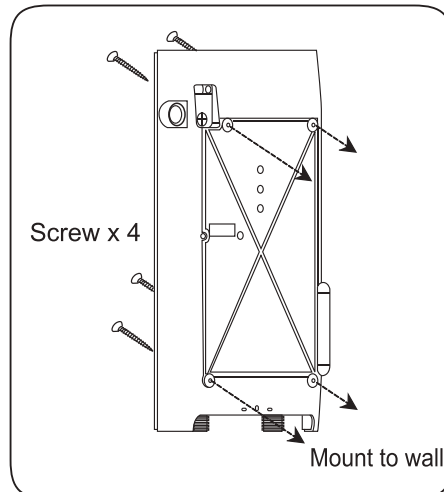

PLUMBING CONNECTIONS

COMPLETE THIS PROCESS BEFORE WIRING CONNECTION

CONNECTION PROCEDURE:

Connect the water supply to the inlet of the shower via 15mm copper, stainless steel or plastic pipe using a 15mm x 15mm elbow compression fitting. Do not use excessive force when making these connections.

FITTING THE STOP VALVE

Fit the Stop valve (Warning: Conductive Valve shall not be used) by secure to the unit Inlet.

Note:

It is compulsory to have the product installed with stop valve (with filter) provided, failing which, dirt particles may cause failure of flow switch assembly.

Ensure the supplied washers are in place before connecting inlet and the Stop Valve.

Fit the other point of Stop Valve to the incoming water supply.

Ensure that the backplate of the unit is flat on the wall and positioned squarely. Tighten the fixing screws.

Turn on the water supply and check for leaks in the pipework connection to the shower.

NOTE: At this stage no electricity can flow through the unit.

ELECTRICAL CONNECTION

WARNING: THIS UNIT MUST BE EARTHED.

SWITCH OFF THE ELECTRICITY SUPPLY.

The cable entry points are shown in the figure below. Determine the cable entry to the unit.

- Side entry – Poke the electrical cable through the Rubber grommet.
- Back entry - break the thinned marked \oplus ,

Route the cable into the shower unit and connect to the terminal block (Fig. 1) as follows:-

Earth cable to terminal marked \oplus
 Neutral cable to terminal marked 'N'
 Live cable to terminal marked 'L'

IMPORTANT: Fully tighten the terminal block screws and ensure that no cable insulation is trapped under the screws. Loose connections can result in cabling overheating. DO NOT switch on the electricity supply until the cover has been fitted.

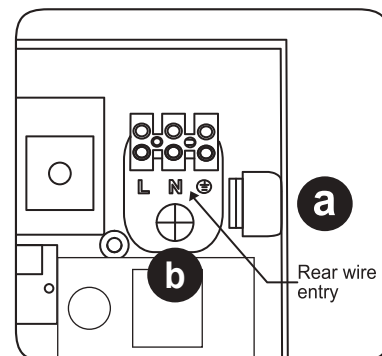
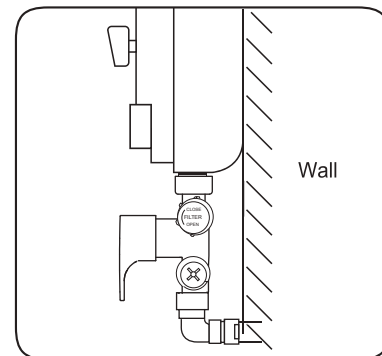
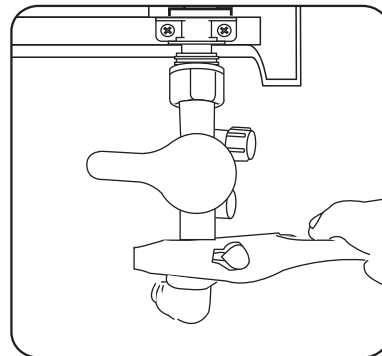
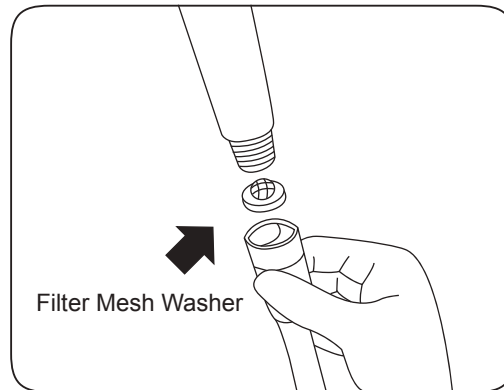

Fig. 1

FITTING THE HOSE AND SPRAY HEAD

Fit the flexible hose (Warning: Metallic / Chromed Hose shall not be used) by connecting to the unit outlet (Left side) and handshower. Ensure the supplied washer is in place at the outlet and the filter mesh at the handshower.



Place the handshower into the holder and check that it fits correctly.

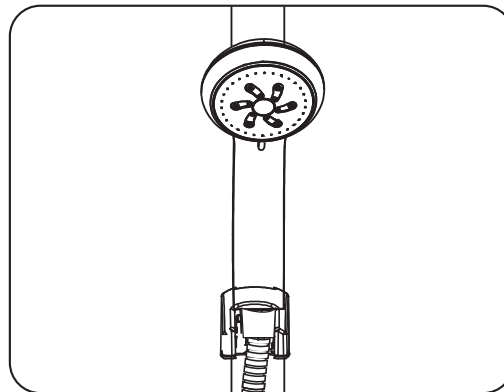

Important:

It is the conical end of the hose which grips into the holder. The handshower will not fit in the holder without the hose attached.

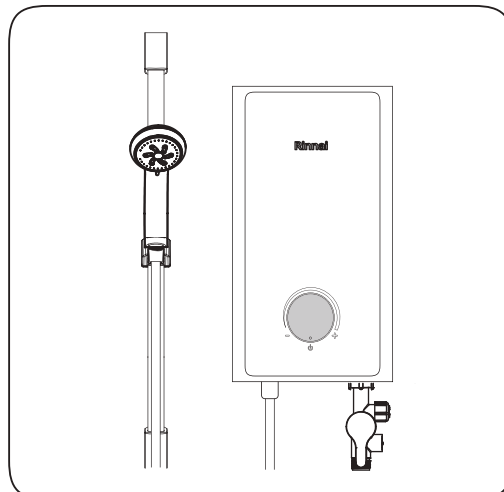

DO NOT switch on the electricity supply until the following procedure has been completed and the cover has been fitted.

The first operation of the shower is intended to flush out any remaining unit dirt particles, and to ensure the heater unit contains water before the elements are switched on.

This operation must be carried out with the flexible hose screwed to the outlet but without the sprayhead attached. Ensure the outlet of the flexible hose is directed to waste.

Turn ON the main water supply. Check if any water leaks from the pipe line.

Secure the cover in position with screws. **DO NOT OVERTIGHTEN.**

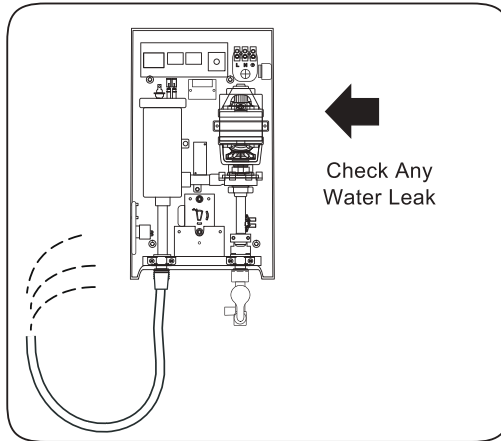

TESTING TEMPERATURE SETTING

Switch on the main electric supply to the shower at the isolating switch.

The  ON/OFF sign and Rinnai Logo wording will light meaning the unit is ON.

Turn the knob clockwise to  sign, the  and  sign will Light.

Turn the knob anti-clockwise to ; the  and  sign will switch OFF again.

Continual turn of the knob clockwise, the temperature of the water should rise slightly.

Allow a few seconds for the warm water to reach the handshower, this shows that the power setting is operating correctly.

Set the shower temperature by rotating the Knob as necessary. Turn the knob clockwise for hotter water and anticlockwise to  position for cooler water.

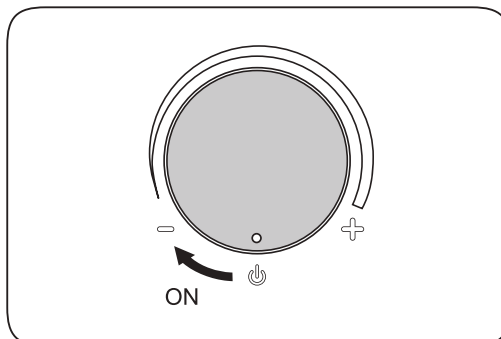

TESTING RCD (For RCD model only)

Test the RCD by pressing the TEST Button. The Rinnai and Ⓞ sign light will turn OFF.

Press the RESET Button to switch ON the unit again. This shows the RCD should be in good condition.

Note!

If nothing happen when these button are pressed, do not use the heater, and contact your agent immediately.

Never attempt to repair the unit by yourself.

Fit the shower fittings. Once the riser rail is fitted, the shower is ready for normal use.

Turn ON the Pump Speed Control Knob at the bottom left of the heater to test run the pump. If the Shower is not hot enough, adjust the speed knob slower to reduce speed in order to get the desired temperature. **(For Pump Model Only)**

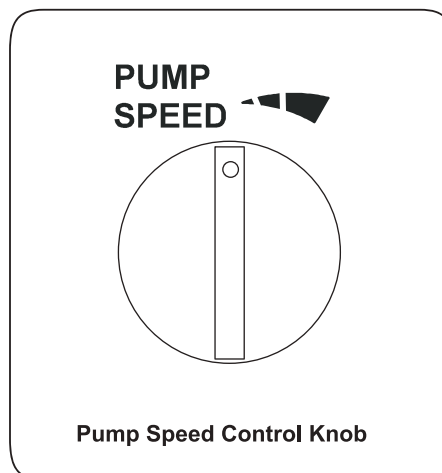
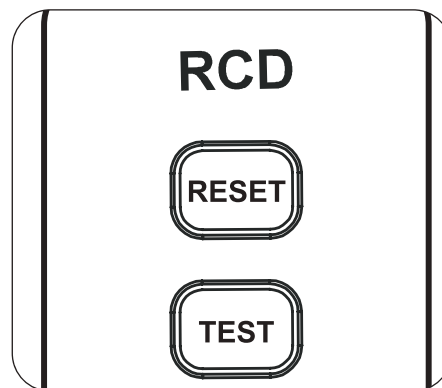

Important: Ensure the commissioning procedure has been carried out.

To start the shower, turn the stop valve handle anti-clockwise to allow water to flow through the unit.

To stop the shower, turn the stop valve handle clockwise back to the position as shown in the figure.

CAUTION: Do Not Test the Stop Valve under dry condition.

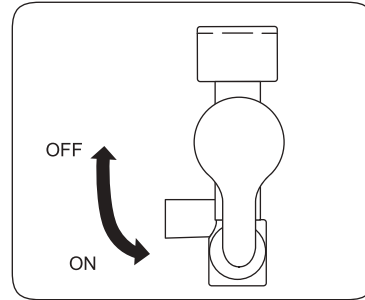

The built-in Pump can be independently controlled by using the Pump Speed Control Knob. In low pressure areas (below 15 p.s.i.) adjust pump speed to obtain desired spray of water. If water pressure is high (over 15 p.s.i) turn 'OFF' the Pump Speed Control Knob in order to achieve hotter shower. **Note: It is recommended that the pump should be operated at intervals of 30 minutes with 30 minutes rest.**

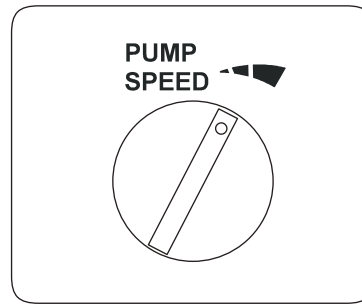

To adjust the shower temperature

The shower temperature is altered by increasing or decreasing the Power Control via the Control knob.

To increase the shower temperature
Turn the Control Knob clockwise towards the + sign; this will increase the water temperature.

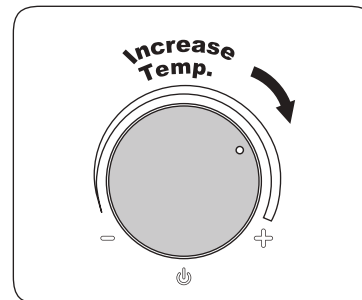

To decrease the shower temperature
Turn the Control Knob anti-clockwise towards the - sign; this will decrease the water temperature.

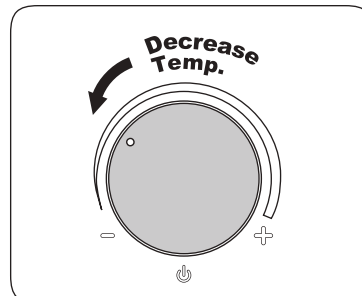

CAUTION: Be certain the showering temperature is satisfactory by testing with your hand before stepping under the sprayhead. There will be always a time delay of 10 to 15 seconds between selecting a flow rate and the water reaching the stable temperature for that flow rate. It is recommended that persons who may have difficulty understanding or operating the shower controls should not be left unattended whilst showering. Special consideration should be given to young children and the less able bodied.

CLEANING

NOTE: Do Not Use Thinner, Alcohol or Petrol

Many household cleaners contain abrasives and chemical substances, and should not be used for cleaning plated or plastic fittings. These finishes should be cleaned with a mild washing up detergent or soap solution, and then wiped dry using a soft cloth.

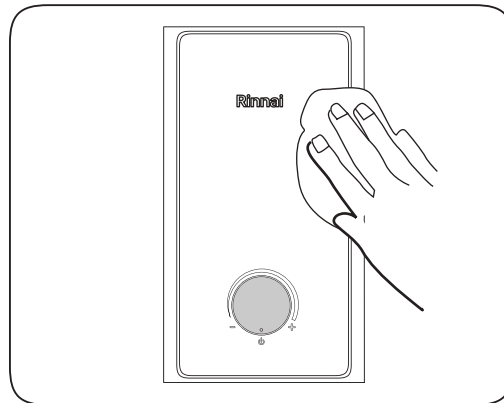

FILTER MAINTENANCE

It is recommended that the filter is periodically cleaned in order to maintain the performance of the shower.

Remove the filter head from the stop valve. Remove the Filter Net and clean it using soft brush then wash it under running water. Ensure all dirt particles are removed.

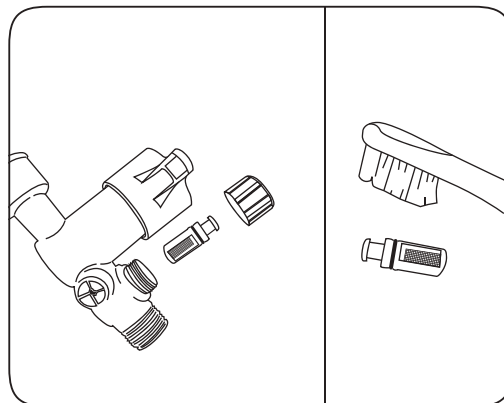

Fit it back after washing the filter.

**TESTING RCD
(For RCD Model Only)**

Test the RCD at least once a month.

Turn on the unit with electric power and water supply.

Test the RCD by gently pressing TEST button. The RCD should be automatically tripped to OFF position. Press RESET to turn the unit back on.

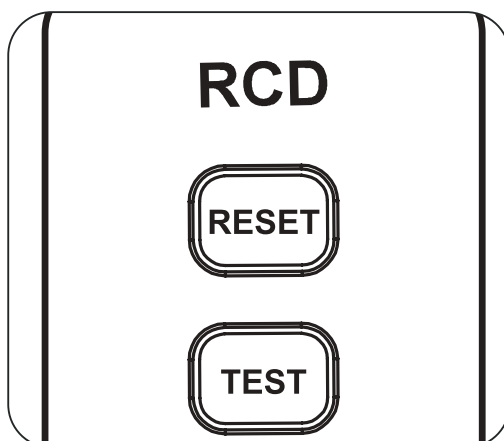

Fault / Symptom	Cause	Remedy
1. No shower coming out from the heater.	1.1 Interrupted Water Supply	Check whether the water supply is available.
	1.2 Incoming water supply stop valves is turned off.	Turn on stop valve.
	1.3 Dirt particles blocking inlet / outlet hole	Blocked sprayhead - clean or replace sprayhead. Blocked filter – see 'filter maintenance'.
2. Heater not functioning	2.1 Interrupted Power Supply	Check if a main power cut. Check other appliances and if necessary, contact the local Electricity Supply Company.
	2.2 Insufficient water supply to trigger flow switch	Heater requires minimum 2 litres/min water flow rate.
	2.3 Thermal Cut-Out has operated	Have the shower unit checked by a competent electrician or contact Customer Service.
	2.4 Malfunctioning on Flow Switch	
	2.5 Electrical malfunction	
3. Water too hot	3.1 Not enough water flowing through the Unit.	Blocked sprayhead - clean or replace sprayhead. Blocked filter – see 'filter maintenance'.
	3.2 Increase in ambient water temperature.	Switch to lower power setting and readjust flow rate to give the required temperature.
4. Water is not hot enough	4.1 Too much water flow.	Reduce the flow rate by Pump Speed knob
	4.2 Decrease in ambient water temperature	Switch to higher power setting and adjust the Pump speed knob to reduce speed in order to get on the desired temperature.
	4.3 Electrical malfunction.	Have the shower unit checked by a competent electrician or contact Customer Service.
5. Water supply turn off but the indicator light is still ON	5.1 Flow Switch malfunction	Have the shower unit checked by a competent electrician or contact Customer Service.
	5.2 Faulty Triac	
6. Motor tone increases	6.1 Interrupted Water Supply	See 1.1 and 3.1
	6.2 Faulty Pump Unit	Wait for internal pump to cool down. If still faulty contact Customer Service.

Model Electrical Rating	– Available in 3.3kW, 230V AC, 50Hz
Minimum Water Flow Rate	– 2 liters/min
Maximum Water Pressure	– 380 kPa (55 psi)
Minimum Water Pressure	– 20 kPa (2.9 psi)
Shower Temperature Control	– Electronic Control
Water Connection	– 15mm dia. (1/2" BSP)
Dimension	– 390mm x 220mm x 87mm
Gross Weight (Normal Shower Set)	– 3.30 kgs
Net Weight (Normal Shower Set)	– 1.80 kgs
Gross Weight (Rainshower)	– 5.0 kgs
Net Weight (Rainshower)	– 1.80 kgs

Schematic Wiring Diagram

SCHEMATIC WIRING DIAGRAM (REI-NP SERIES W/O RCD)

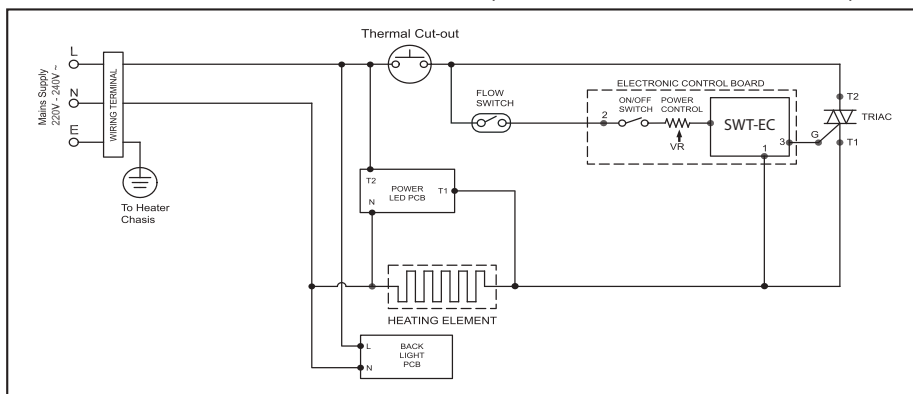

Model Electrical Rating	– Available in 3.8kW, 240V AC, 50Hz
Minimum Water Flow Rate	– 2 liters/min
Maximum Water Pressure	– 380 kPa (55 psi)
Minimum Water Pressure	– 20 kPa (2.9 psi)
Shower Temperature Control	– Electronic Control
Water Connection	– 15mm dia. (1/2" BSP)
Dimension	– 390mm x 220mm x 87mm
Gross Weight (Normal Shower Set)	– 4.30 kgs
Net Weight (Normal Shower Set)	– 2.80 kgs
Gross Weight (Rainshower)	– 6.0 kgs
Net Weight (Rainshower)	– 2.80 kgs

Schematic Wiring Diagram

SCHEMATIC WIRING DIAGRAM (REI-AP SERIES C/W E2C)

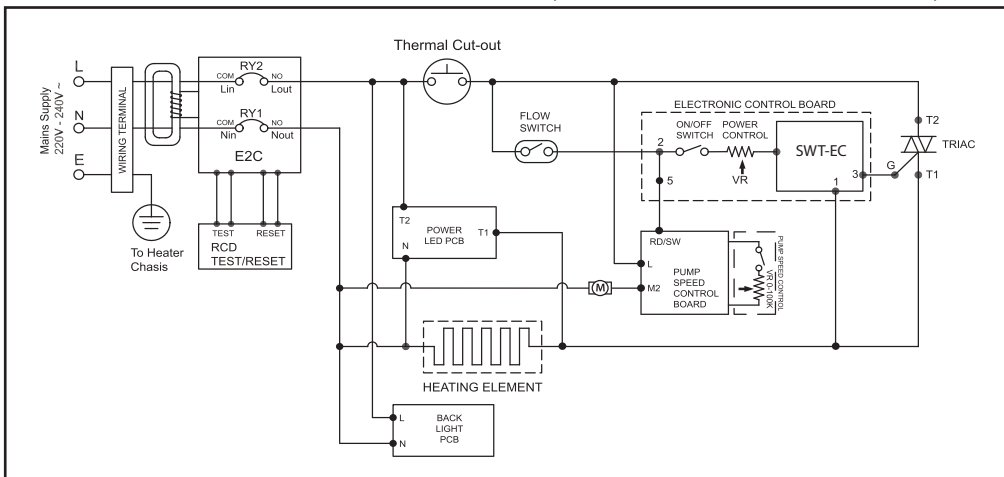

Model Electrical Rating	– Available in 3.3-3.8kW, 230-240V AC, 50Hz
Minimum Water Flow Rate	– 2 liters/min
Maximum Water Pressure	– 380 kPa (55 psi)
Minimum Water Pressure	– 20 kPa (2.9 psi)
Shower Temperature Control	– Electronic Control
Water Connection	– 15mm dia. (1/2" BSP)
Dimension	– 390mm x 220mm x 87mm
Gross Weight (Normal Shower Set)	– 3.90 kgs
Net Weight (Normal Shower Set)	– 2.30 kgs
Gross Weight (Rainshower)	– 5.5 kgs
Net Weight (Rainshower)	– 2.30 kgs

Schematic Wiring Diagram

SCHMATIC WIRING DIAGRAM (REI-DP SERIES W/O RCD)

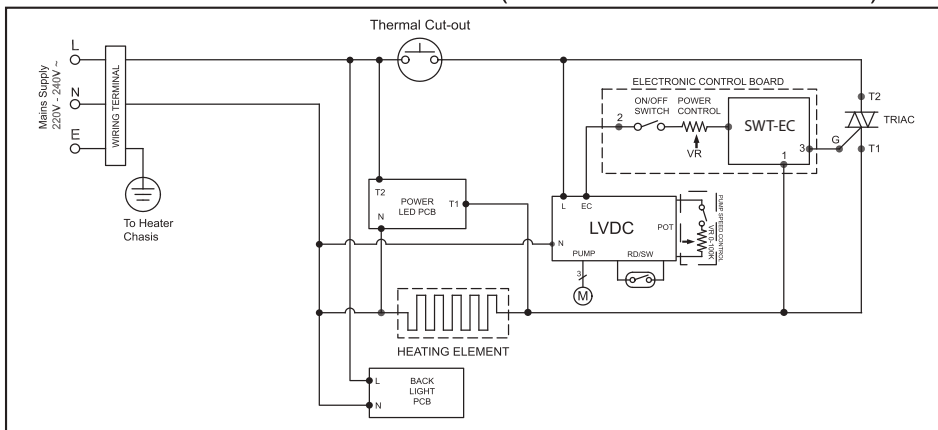

SCHMATIC WIRING DIAGRAM (REI-DP SERIES C/W E2C)

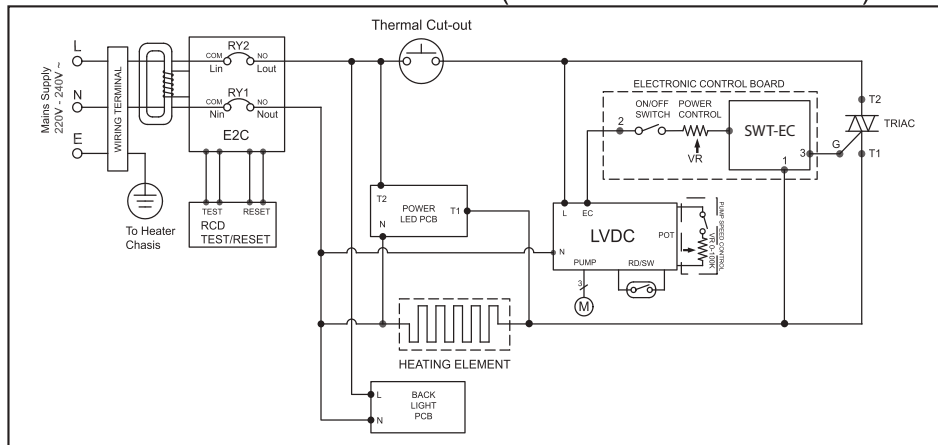

Rinnai (Malaysia) Sdn Bhd

D2-3, Block D2,
Pusat Perdagangan Dana 1,
Jalan PJU 1A/46, PJU 1A,
Ara Damansara,
47301 Petaling Jaya,
Selangor Darul Ehsan, Malaysia.
Toll Free. 1800 88 8180
Tel. 03 7832 0037 / 0038 / 0039
Fax. 03 7832 0036
Email. customercare@rinnai.com.my
Web. www.rinnai.com.my

Rinnai Holdings (Pacific) Pte Ltd

61 Ubi Road 1,
#02-20 & 21,
Oxley Bizhub
Singapore 408727
Tel. +65 6748-9011
Fax. +65 6745-9240
Email. service@rinnai.sg
Web. www.rinnai.sg