

SUPREMA™

Kitchen Faucet: S3FB-01S

Installation Guide

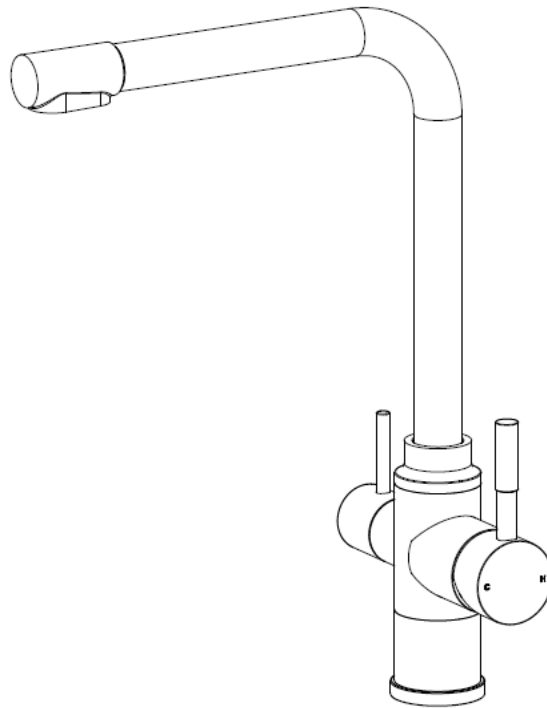

! IMPORTANT! Please read the instructions carefully before installation.

Not suitable for gravity feed systems.

All pipe work must be thoroughly flushed prior to installation – failure to do this will result in foreign materials blocking the flow regulating device and reduce the flow.

Do not conduct hydrostatic test once the tap has been fitted – doing this will cause damage to the ceramic cartridge.

Isolating stop valves are recommended to be fitted to the hot & cold water supply connections for ease of maintenance.

1. Installation

! IMPORTANT! Before installation;
Flush through the pipe work to ensure removal of debris.
Turn off the water mains and close any isolating valves.
Ensure the mounting surface is clean.

1.1 Installing the tap to the mounting deck

Requirements;
Mounting deck - with single 35mm diameter tap hole and thickness of not more than 95mm. Refer Diagram 1.

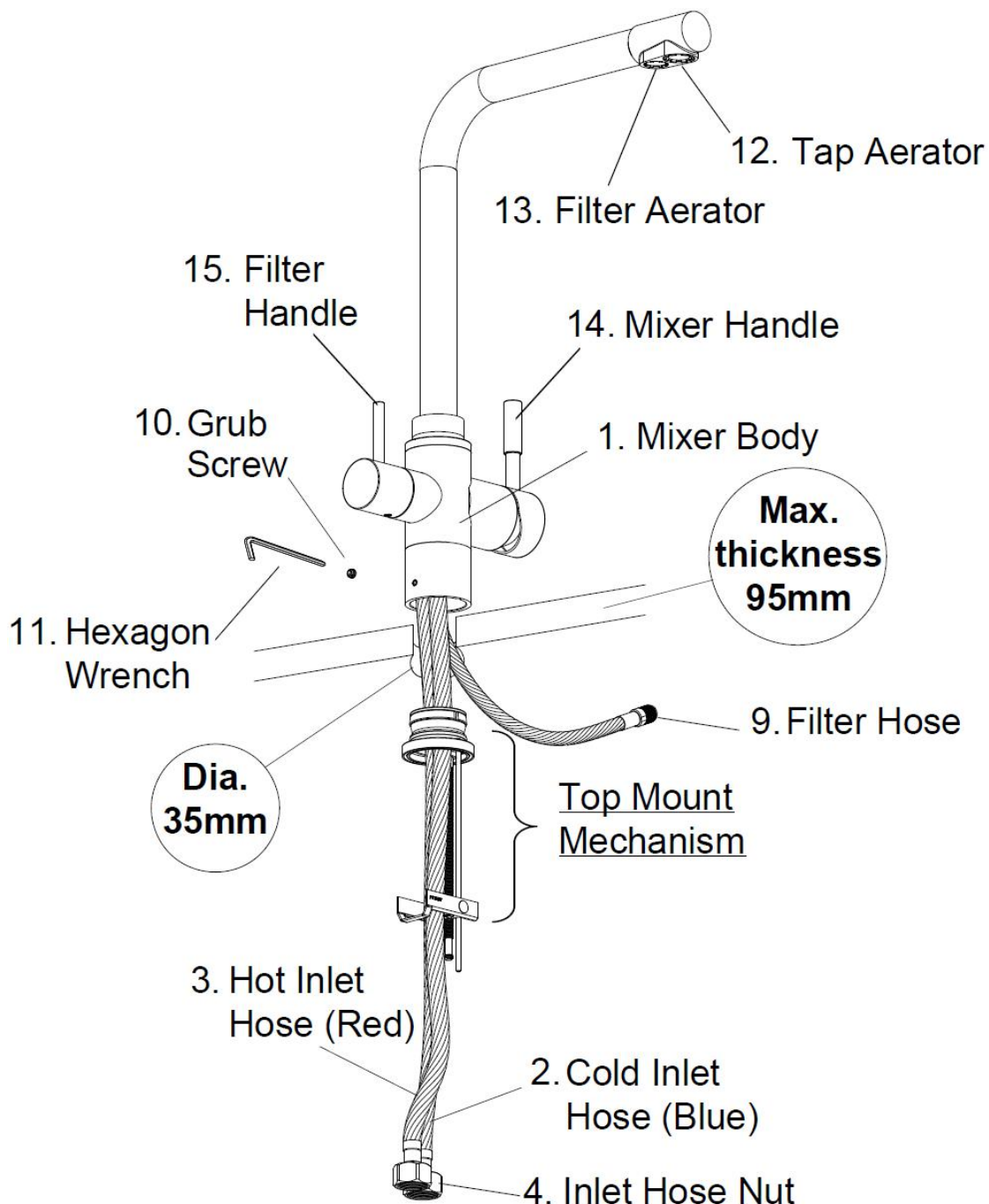

Diagram 1

Tools - battery operated power drill (minimum torque 265 in.lb.) fitted with 'Phillips' screw bit, pliers & adjustable spanner. Refer Diagram 2.

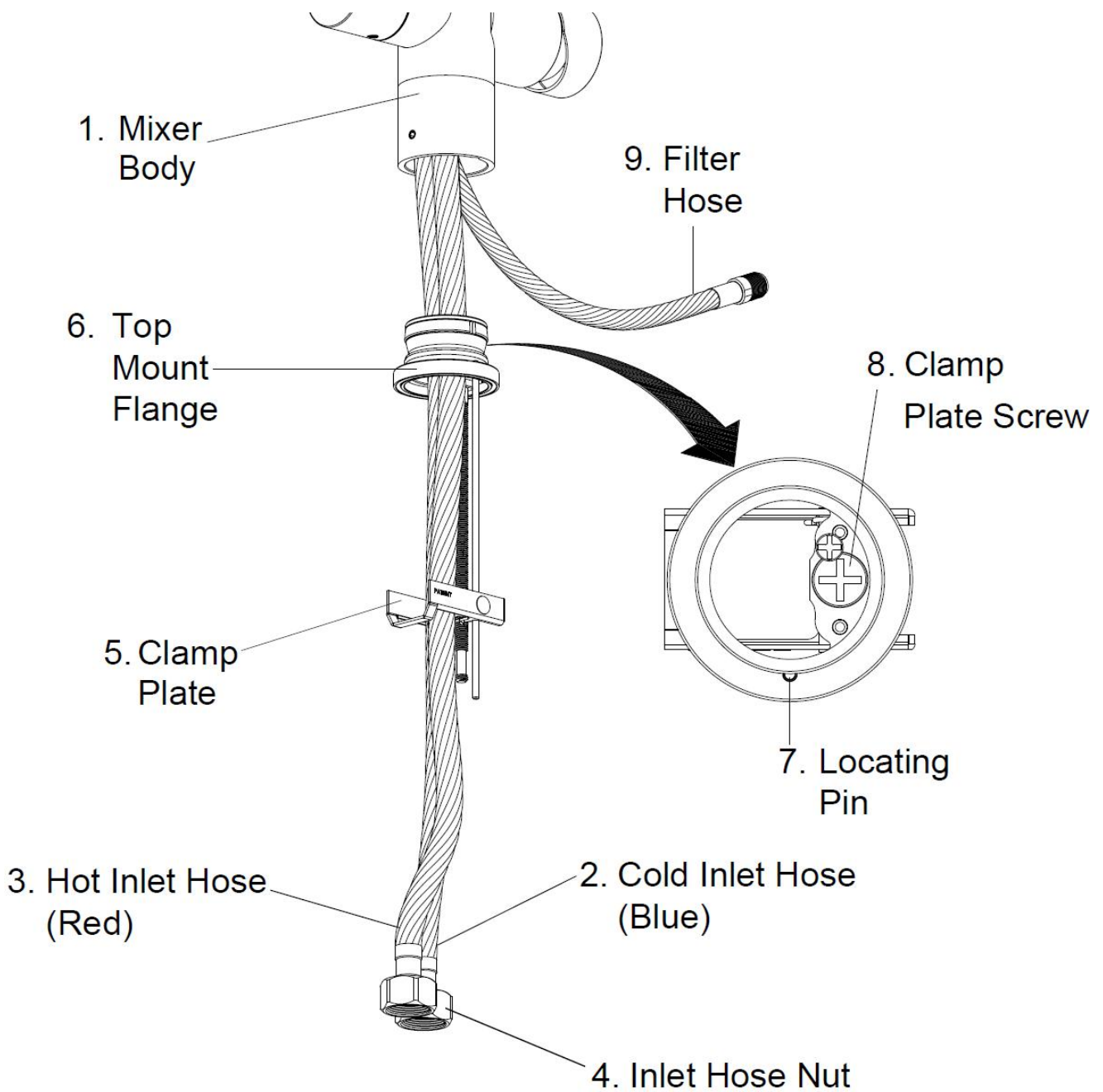
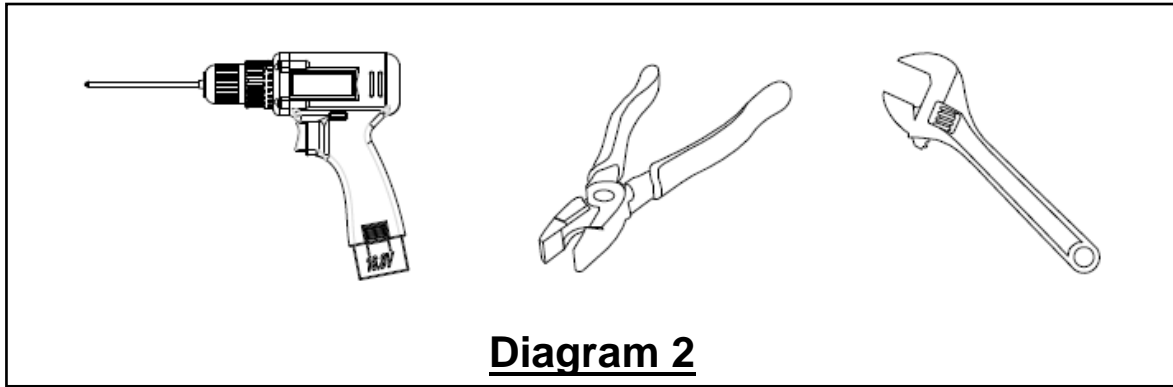

Diagram 3 (Top Mount Mechanism)

Step1 - Place the Top Mount Mechanism over the tap hole

! IMPORTANT! Do not attempt to dismantle the inlet hoses prior to installation!

! IMPORTANT! Do not attempt to insert the filter hose through the tap hole yet at this stage!

● While holding up the Mixer Body ① in one hand, use your other hand to insert the flexible Cold Inlet Hose ② & Hot Inlet Hose ③ through the mounting surface hole.

Insert one hose at a time by first inserting the Inlet Hose Nut ④.

● Next insert the Clamp Plate ⑤. To facilitate a smooth entry, lift up the spring loaded clamp plate and press it toward the inlet hoses. Refer Diagram 4.

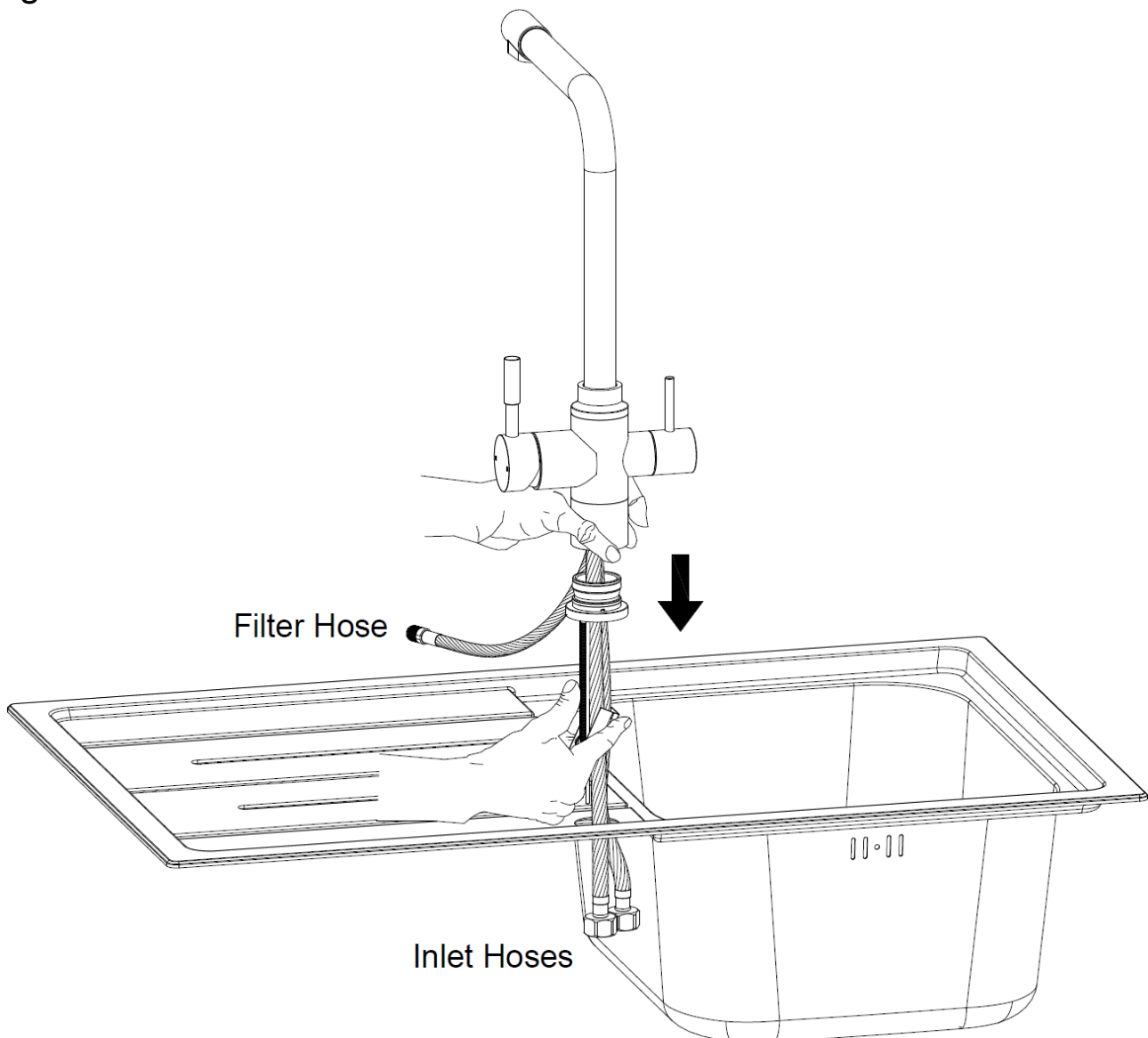

Diagram 4

Step 2 – Align the Top Mount Flange

- Once the clamp plate is through, carefully place the mixer body down on the sink drainer. (Use the velvet tap bag to line the surface to prevent scratches to the mixer or drainer).
- Correctly adjust the orientation of the Top Mount Flange ⑥ such that the Locating pin ⑦ is in the 6 o'clock position. Refer Diagram 5.

! IMPORTANT! While doing this, carefully also ensure that the top mount flange is centrally positioned over the tap hole and not towards one side.

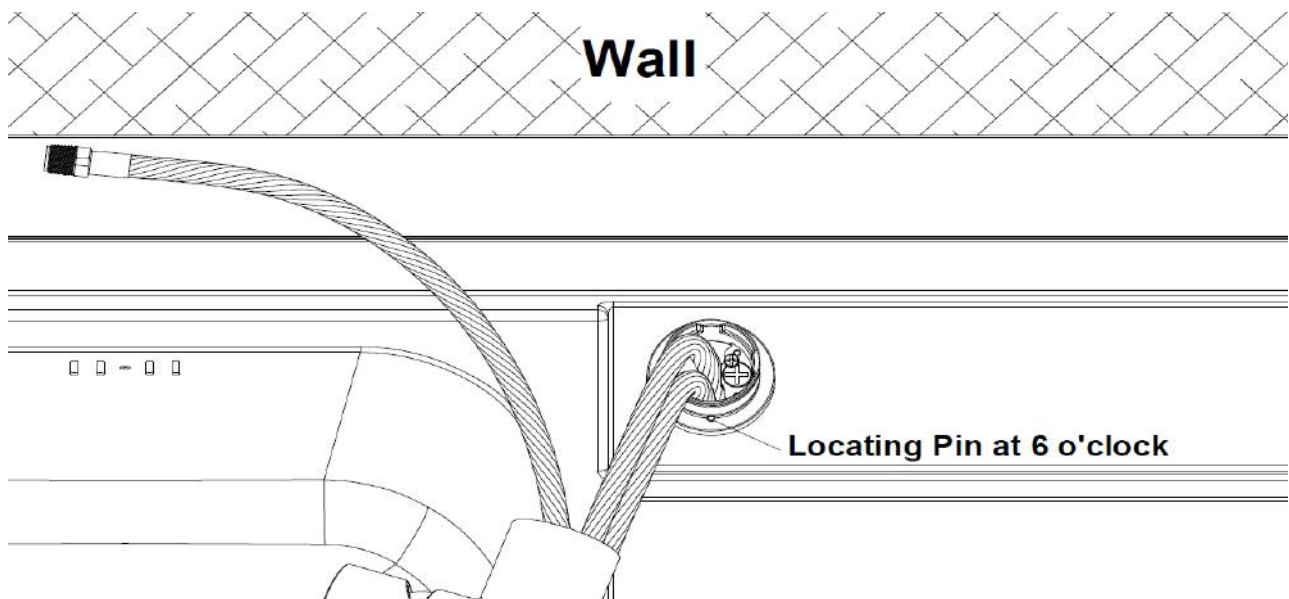

Diagram 5

! IMPORTANT! Place the mixer close to the tap hole to prevent the inlet hose from moving up and lifting up the clamp plate. Failure to adhere to this might result the clamp plate getting wedged in the mounting surface hole in Step 3. Refer Diagram 6 & Diagram 7.

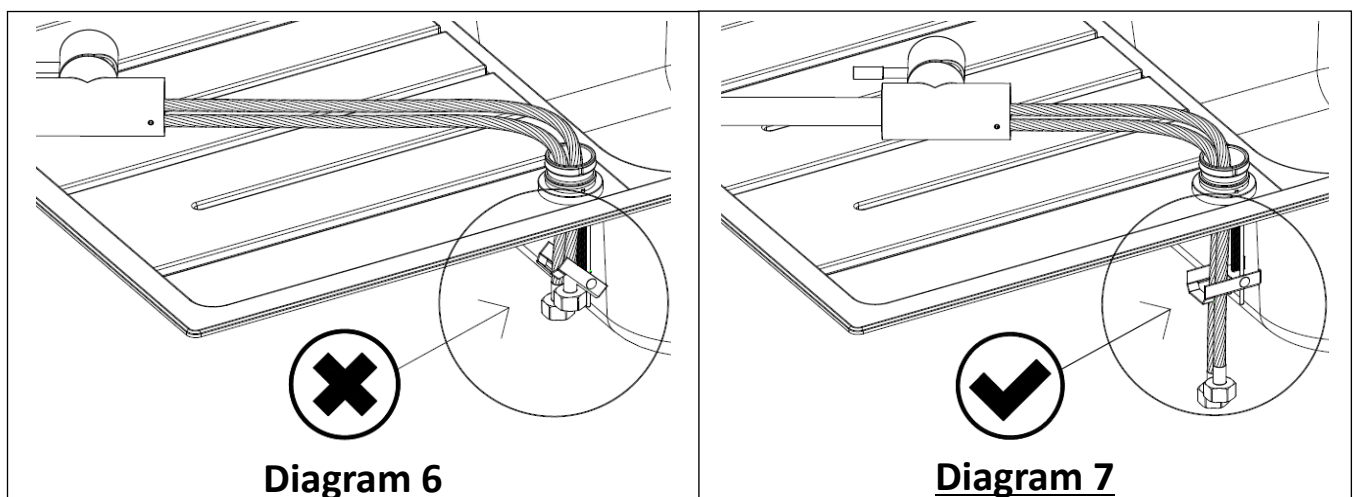

Diagram 6

Diagram 7

Step 3 - Secure the Top Mount Mechanism to the mounting surface

- Using a battery operated power drill set to the highest torque setting, turn and tighten the Clamp Plate Screw (8) while holding down the top mount flange to ensure it does not move out of position. Refer Diagram 8.

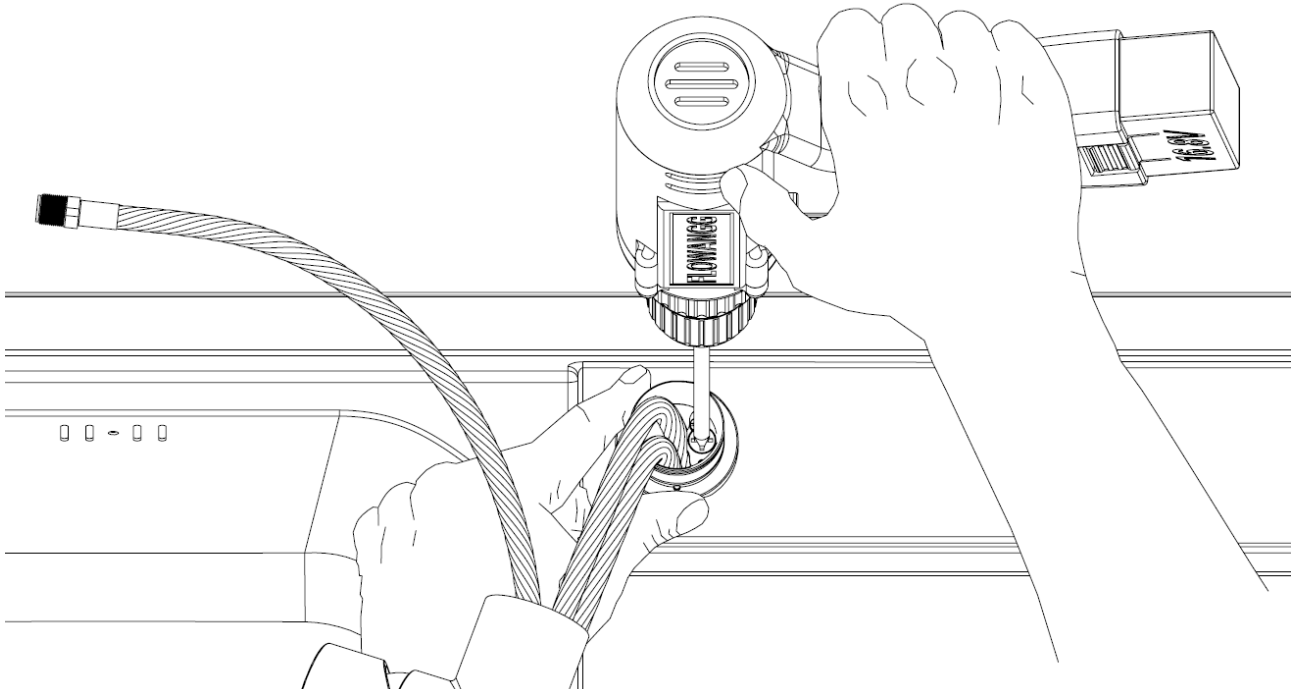

Diagram 8

Step 4 – Insert the Filter Hose

- Next carefully insert Filter Hose (9) through the top mount flange. Refer Diagram 9.

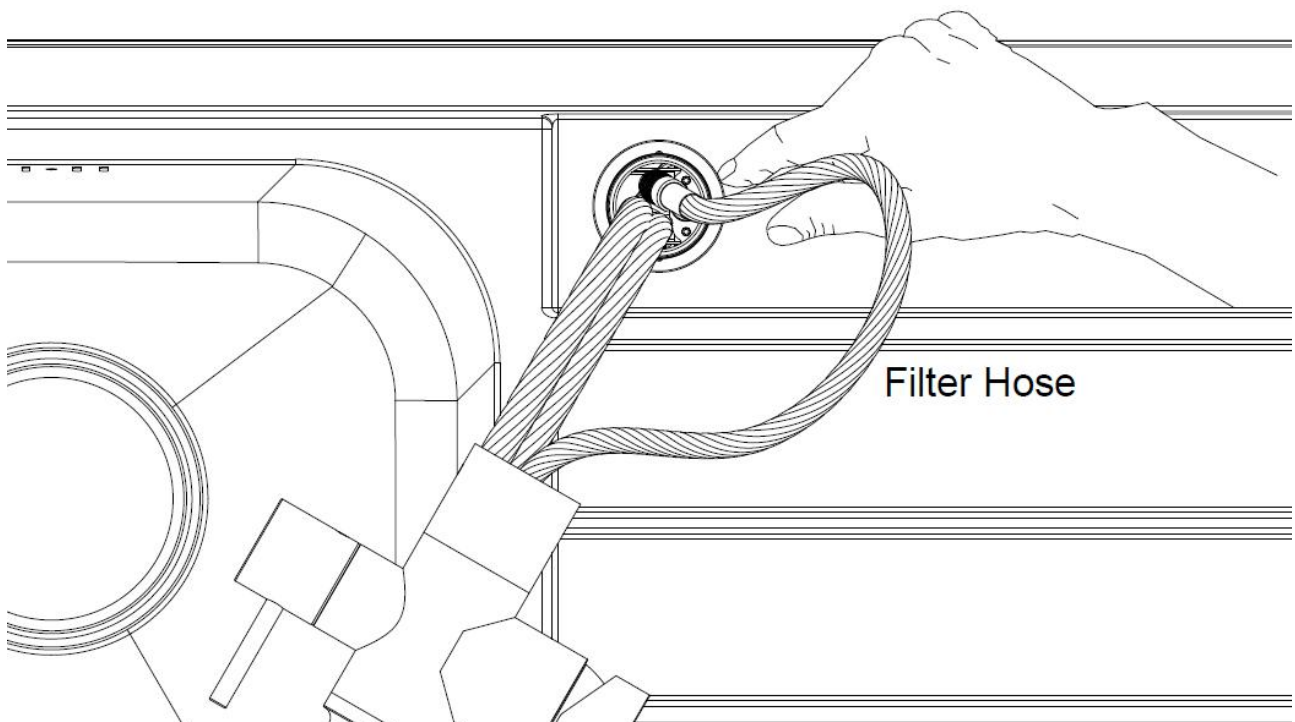

Diagram 9

Step 5 – Fit the Mixer Body onto the Top Mount Mechanism

- Slide the mixer body base on to the top mount flange.

- Align the tap with the handle on the right.

When in the correct position the locating pin will perfectly align with the corresponding slot in the mixer body, allowing the mixer body to sit flush on the top mount flange.

- Turn and tighten Grub Screw ⑩ using the Hexagon Wrench ⑪ to secure the tap. Refer Diagram 10.

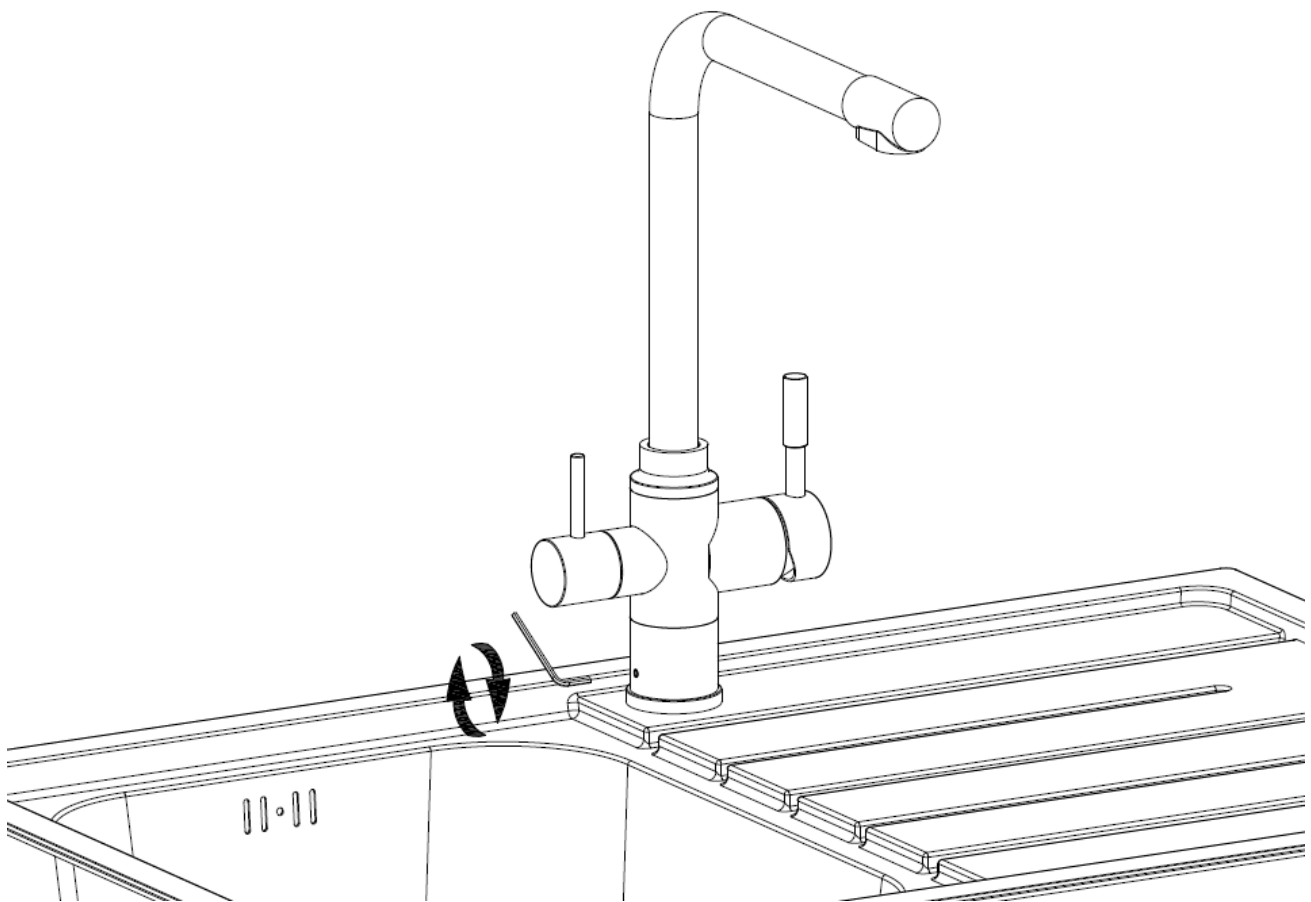

Diagram 10

1.2 Connect the supplies

Make the tap filter hose & inlet hoses connections as illustrated in Diagram 11.

First using a suitable adapter, connect the tap filter hose to the filter line (supplying filtered water).

Next connect the tap Hot and Cold inlet hoses to their respective incoming water supply. For easy identification the flexible inlet hoses have been color marked red (hot) and blue (cold).

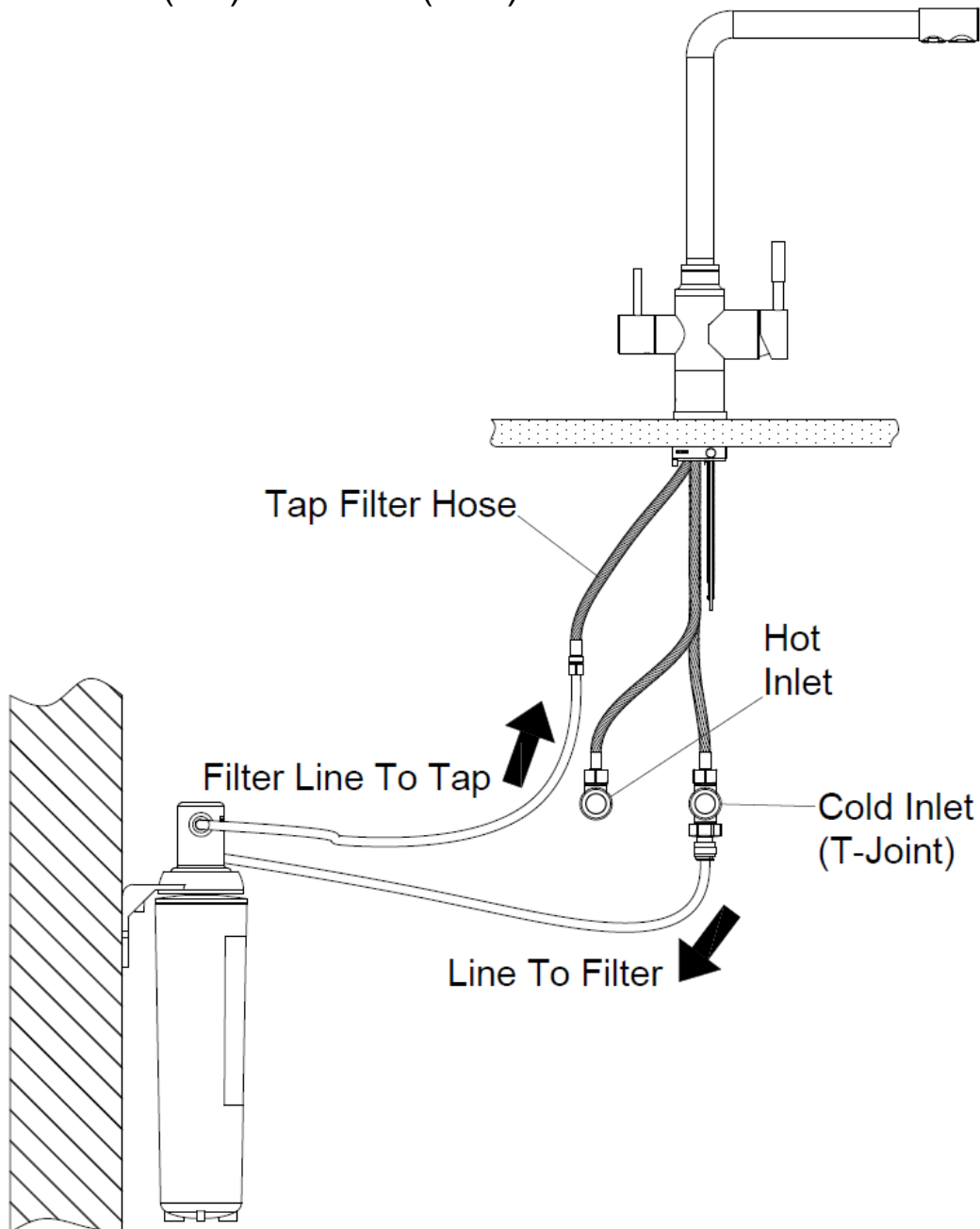

Diagram 11

*** Please note that the water filter, filter lines, adapters and T-joint in the diagram above are for illustration purposes only and are not included with the kitchen faucet.**

! IMPORTANT! Ensure when connecting the flexible inlet hoses do not have sharp bends, kinks or twists. Failure to adhere to the above guidelines may result in drop of performance and also lead to damage to the flexible inlet hoses.

Refer to the Diagram 12 & Diagram 13 with recommendations below.

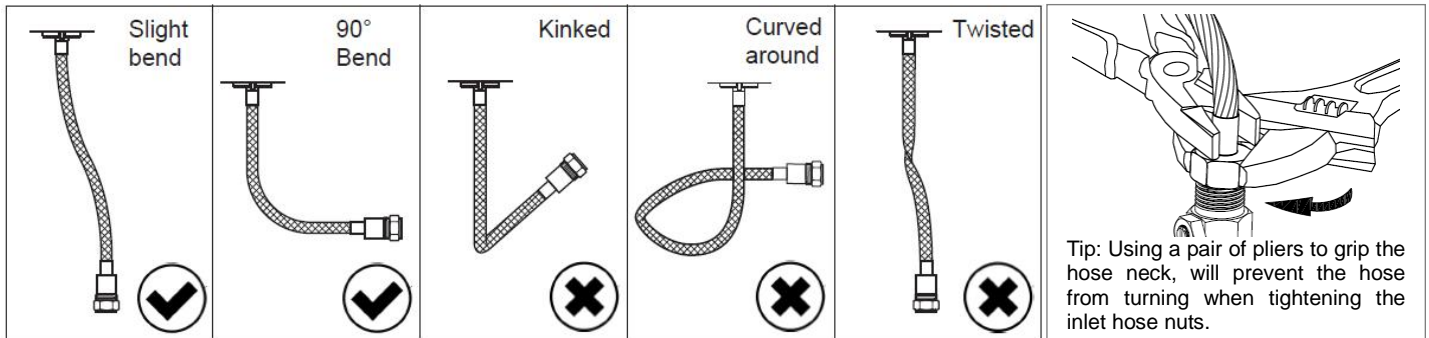

Diagram 12

Diagram 13

1.3 Turning on the supply and setting the LED filter indicator counter.

Turn on the inlet stop valves and check for leaks.

Next turn on the mixer taps to purge air from the system and until water flows in a steady stream.

Turn off the mixer and remove the Tap Aerator (12) & Filter Aerator (13) and check for debris and clean if required.

Replace and tighten back the aerator using a spanner (to prevent removal by hand).

Finally, reset the filter indicator counter by following instructions Resetting the LED Filter Indicator, on page 11.

! IMPORTANT! Ensure that the LED filter indicator is reset before first use.

2. Operation

Tap water operation

- Move the Mixer Handle ⑭ to the right (down and away) from the tap body to begin and increase the water flow. Refer Diagram 14.
- To slow down or stop water flow push lever up. Refer Diagram 15.
- Turn the lever to the front to increase water temperature or to the back to decrease water temperature. Refer Diagram 16.

To start
water flow

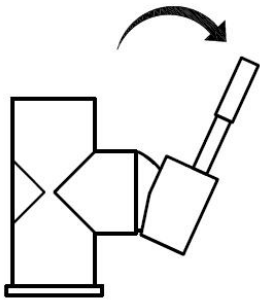

Diagram 14

To stop
water flow

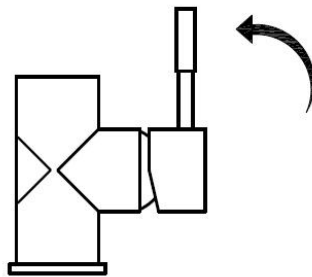

Diagram 15

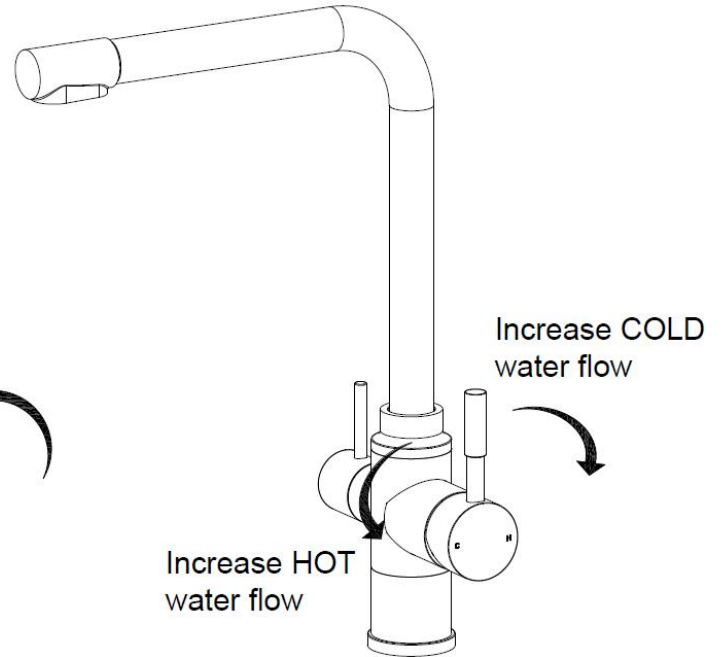

Diagram 16

Filter water operation

Turn the lever on the left side to the front to begin and increase the water flow of the filtered water. Refer to diagram 17.

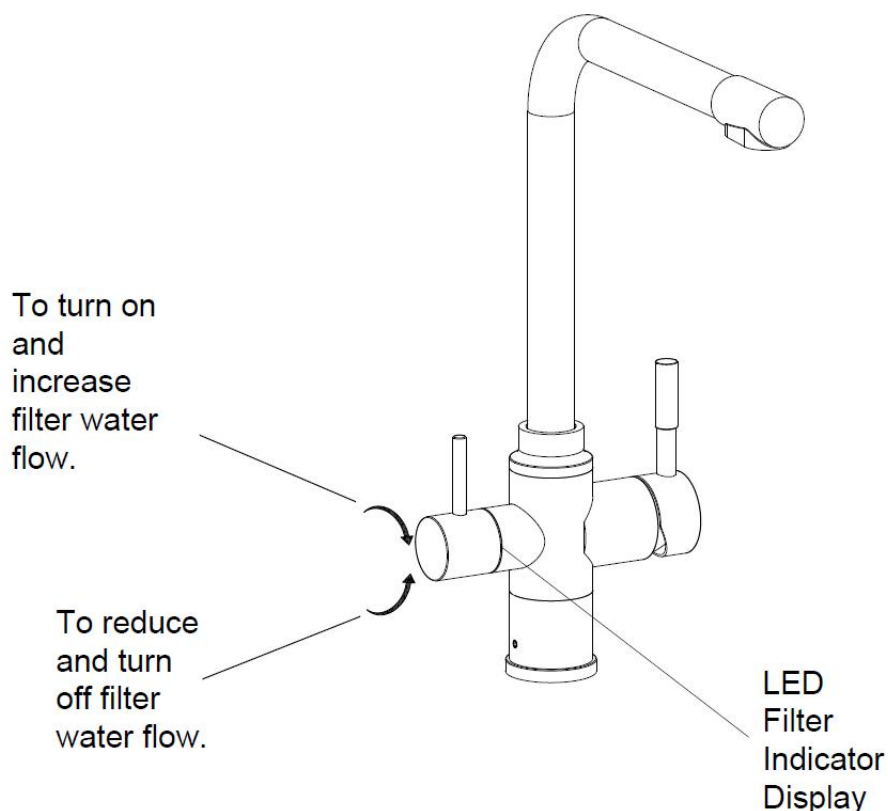

Diagram 17

LED Filter Indicator

The Led Filter Indicator is programmed to prompt you that the water flow has surpassed 8000litres and needs replacement.

It will light up in Blue (pulsating glow) to indicate the water filter is good to use and light up in Red (pulsating glow) indicating it's time to service or replace your filter cartridge.

Resetting the LED Filter Indicator

To reset and begin a fresh cycle, make 5 quick turns of the filter handle within 3 seconds from off position to on and back to off position.

! **IMPORTANT!** Ensure that the LED filter indicator is reset before first use.

Battery

Contact the service centre to have the battery replaced.

*** The battery is integrated with the filter water handle and a new handle will be installed.**

3. Cleaning

Your fitting comes with a high quality finish and should be treated with care to preserve it.

Always use a soft damp cloth with mild detergent to wipe clean the fittings.

! IMPORTANT! Avoid using abrasive detergents, cleaning powders, scouring pads as they will damage the surface and cause scratches.

! IMPORTANT! Never use strong disinfectants, cleaners containing hydrochloric acid or phosphoric acid as they will cause serious damage to the finish.

4. Technical Specifications

Inlet Connections: 1/2" BSP

Dimensions:

Operating Pressure:
150kPa-500kPa (Should the pressure exceeds 500kPa; a pressure limiting valve must be installed.) For optimum performance both the hot and cold water pressure should be equal.

Temperature: Max hot water temperature 70°C.

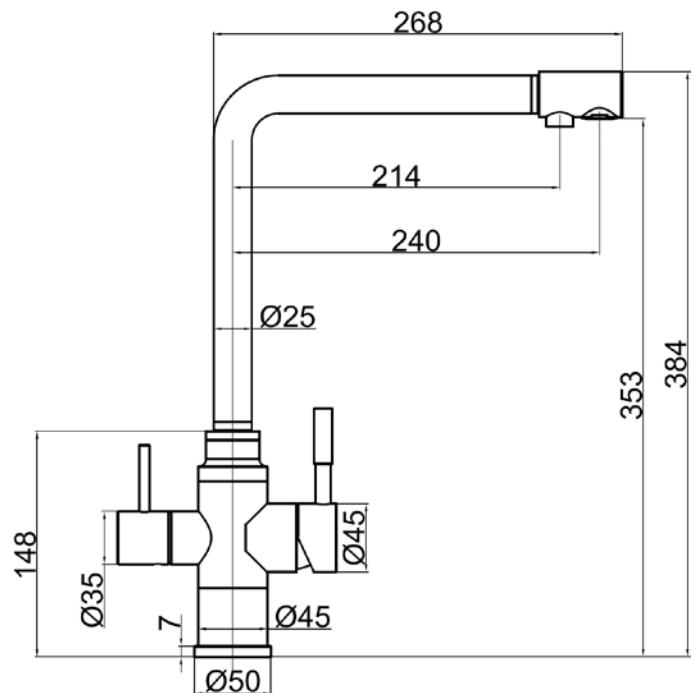

RINNAI (M) SDN BHD

D2-3-G & D2-3-1, Block D2,

Pusat Dagangan Dana 1,

Jalan PJU 1A/46, PJU 1A,

Ara Damansara, 47301 Petaling Jaya,
Selangor, Malaysia.

Customer Care Line: 1 800 - 88 - 81 80

Tel +6 03-7832 0037/38/39

Fax +6 03-7832 0036

Email: customercare@rinnai.com.my

Website: www.rinnai.com.my